

ABOUT RADIO WAVES, INC.

Radio Waves is a recognized leader in the wireless communications industry as a proven supplier of innovative, high quality, microwave antennas backed by the best service and support in the industry. With an extensive product offering covering 1.5 to 80 GHz, Radio Waves designs and manufactures these products from its Billerica, Massachusetts headquarters for fixed broadband wireless applications, internet service providers, cellular and PCS/GSM base station interconnects, WiMAX networks, campus environments, private networks, and electronic newsgathering systems.

Founded in 1983, Radio Waves has a long history of innovative mechanical and electrical designs. Radio Waves supplies these designs to major OEM customers, as well as offering products through distribution channels.

Radio Waves is the world leader in Microwave Antenna Innovation. Working in fast-paced environments, Radio Waves' customers require off-the-shelf products with delivery times ranging from two weeks to overnight. With manufacturing facilities in both the United States and the United Kingdom, Radio Waves can meet these demands. Having multiple facilities provides localized material, which reduces freight costs and delivery times. Enhanced global logistics is part of the value we provide our customers.

All Radio Waves antenna models feature field-proven designs and construction. These antennas are designed to withstand harsh environmental conditions. Our mounts are designed for ease of installation and durability. With hundreds of thousands of antennas in the field, Radio Waves has built a reputation for quality.

In 2001, Radio Waves became a registered ISO 9001: 2000 company to ensure our customers the highest quality service and products available within the industry. Radio Waves quality products are supported with the longest warranty program in the industry. Through our superior quality, Radio Waves has fast become a world-leading supplier of microwave antenna products.

Please refer to the specifications within this catalog to determine which antenna is right for your system requirements. For more information, contact Radio Waves directly or through one of our authorized distributors. Radio Waves is also working towards improving the environment. In 2007 Radio Waves became ISO 14001 certified and our microwave antennas are RoHS compliant. We continue to strive toward doing our part to protect our world.

United States Headquarters:

Radio Waves, Inc.
495R Billerica Ave.
N. Billerica, MA 01862
Tel: 978-459-8800
Fax: 978-459-3310
e-mail: sales@radiowavesinc.com
www.radiowavesinc.com

United Kingdom Facility:

Radio Waves, Inc.
36-38 Waterloo Rd.
Cricklewood
London NW2 7UH



015



TABLE OF CONTENTS



ANTENNA CONFIGURATION	4
RADIO WAVES PLANNING TOOL	5
MICROWAVE SYSTEMS OVERVIEW	6
TYPES OF MICROWAVE ANTENNAS	7
MICROWAVE ANTENNAS: A TECHNICAL LOOK	
FEED ASSEMBLIES	8-9
ANTENNA TERMINOLOGY	10-11
CABLE	12
ACCESSORIES AND HARDWARE	13
ANTENNA CONSTRUCTION	14
TYPICAL USAGE TABLE & VSWR TO RETURN LOSS CONVERSION CHART	15
POWER CONVERSION TABLE	16
RECTANGULAR WAVEGUIDE REFERENCE TABLE	17
FOCAL LENGTH TO DIAMETER RATIO VS. ANGULAR APERTURE FOR PARABOLIC REFLECTORS	18
RADIO WAVES BROADBAND FIXED WIRELESS PRODUCTS	19
SECTOR SERIES ELECTRICAL SPECIFICATIONS	20-22
OMNI ANTENNA ELECTRICAL SPECIFICATIONS	22
PRO-VIDER SERIES ELECTRICAL SPECIFICATIONS	23
SP SERIES ELECTRICAL SPECIFICATIONS - 1.3 TO 5.8 GHz PRODUCTS	24-26
XCELARATOR®	27
GRID PARABOLIC SERIES ELECTRICAL SPECIFICATIONS	28
FLAT PANEL SERIES ELECTRICAL SPECIFICATIONS	28
RADIO WAVES POINT-TO-POINT PARABOLIC ANTENNAS	29
DISCRIMINATOR™	30
HP AND SP SERIES ELECTRICAL SPECIFICATIONS - 5.8 TO 80 GHz PRODUCTS	31-37
PARABOLIC ANTENNA REGULATORY COMPLIANCES	38-39
ANTENNA DIMENSIONS	40-45
SECTOR & PRO-VIDER SERIES	40
FLAT PANEL AND XCELARATOR SERIES	40
GRID PARABOLIC SERIES	41
HP SERIES	42-43
SP SERIES	44-45
ANTENNA WINDLOADS	46-48
SIDE STRUTS	49
ELLIPTICAL WAVEGUIDE	50-54
FLANGES	55-56
FLEX TWIST WAVEGUIDE	57-58
FLEX TWIST ORDERING GUIDE	59
LMR CABLE	60-64
PRESSURIZATION, GROUNDING KITS	65-68
STANDARD DRUM SIZES, LENGTH CAPACITY CHART FOR LMR CABLE	69
SHIPPING INFORMATION	70-71
TERMS AND CONDITIONS	72
WARRANTY	73

ANTENNA CONFIGURATION MATRIX

Radio Waves' model number system describes 1) the antenna type, 2) the diameter 3) the operating frequency band and 4) the connector.

1) Antenna type: The prefix defines the antenna type:

Use	Description
DP	Deep Dish Parabolic, Plane Polarized
DPD	Deep Dish Parabolic, Dual Polarized
HPCPE	HP Discriminator™ Series Plane Polarized
HPLP	HP Low Profile Shielded, Plane Polarized
HPLPD	HP Low Profile Shielded, Dual Polarized
HP	HP Shielded, Plane Polarized
HPD	HP Shielded, Dual Polarized
OMN	Omni
SP	SP Unshielded, Plane Polarized
SPD	SP Unshielded, Dual Polarized

2) Antenna Diameter: The number selected will determine the antenna size in feet:

Use	Description
1	1 ft (0.3m)
2	2 ft (0.6m)
3	3 ft (0.9m)
4	4 ft (1.2m)
6	6 ft (1.8m)
8	8 ft (2.4m)

3) Frequency Band: The number selected will determine the antenna operating frequency, GHz.

Use	Description
52	5.250 - 5.850
57	5.725 - 6.425
59	5.925 - 6.425
6	5.925 - 7.125
64	6.425 - 7.125
7	7.125 - 7.75
77	7.125 - 8.50
8	7.75 - 8.50
10	10.5 - 10.7
1011	10.5 - 11.7
11	10.7 - 11.7
12	12.2 - 12.7
13	12.70 - 13.25
15	14.25 - 15.35
18	17.7 - 19.7
23	21.2 - 23.6
24	24.25 - 25.25
26	24.25 - 26.50
28	27.3 - 31.3
31	29.5 - 31.3
33	31.3 - 33.4
38	37.0 - 40.0
60	57.0 - 64.0
73	71.0 - 76.0
80	71.0 - 86.0

4) Connector: A Type “N” (Female) Connector is also available. Please add Suffix “NS” to the antenna model number when ordering. “NS” models are non pressurized!

“RS” models will be supplied with flanges.* **These models can be pressurized to 5 psi.**

Other flange types are available, please contact an authorized Radio Waves representative. The electrical specifications for the parabolic antennas notes which flange size is utilized.

Example:

HP4-77RS

High Performance Antenna, 4-ft. (1.2m), 7.125 - 8.50 GHz with CPR112G Interface.

*Please see page 55 for more detail on flanges.

Antenna’s with OEM Direct Connect Interfaces:

Radio Waves, with our innovative patented feed design, has developed numerous OEM interfaces since 1988. These direct connect antennas are available in diameters from 1 ft (0.3m) to 8 ft (2.4m), in frequency bands ranging from 5.9 to 86 GHz. These direct connect interfaces offer an improved overall system performance while reducing system cost and installation time.

RFID: Radio Waves can supply antennas with RFID tags for a small extra fee.

Radio Waves, Inc.

<http://www.radiowavesinc.com>

sales@radiowavesinc.com

RADIO WAVES SYSTEM PLANNING TOOL

RF INDOORS

Antenna Equipment			
ITEM	QTY.	PART NO.	DESCRIPTION
01			Antenna
02			Radome (PSP & SP Series)
03			Optional Side Strut

Waveguide and Accessories			
ITEM	QTY.	PART NO.	DESCRIPTION
04			Flexible Waveguide Top
05			Flexible Waveguide Bottom
06			Elliptical Waveguide
07			EW Connector - Top (Antenna)
08			EW Connector - Bottom (Radio)
09			Hoisting Grip (1 per 200 ft)
10			Angle Adapter Kit (10 per kit)
11			Round Member Adapter (10 per kit)
12			Hangers (10 per kit)
13			Hanger Hardware Kit (10 per kit)
14			Threaded Rod Support Kits
15			Universal Grounding Kit
16			Pressure Window
17			Wall / Roof Feed Thru
18			Cushioned Boot(s)
19			Dehydrator
20			Air Distribution Kit

Antenna Types:

High Performance, Shielded
Standard Parabolics, Non-Shielded

Transmission Line:

Elliptical Waveguide

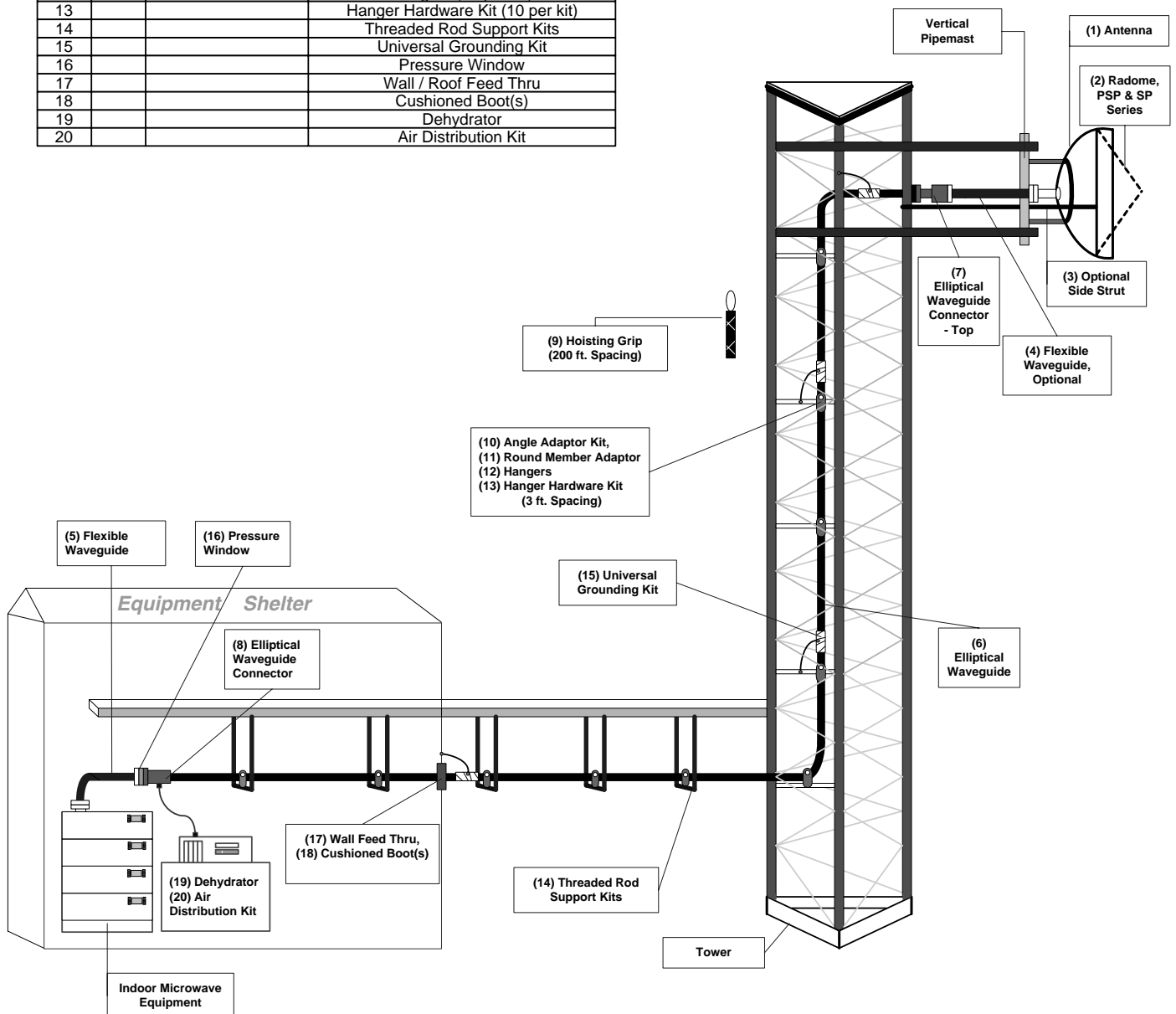

MICROWAVE SYSTEMS OVERVIEW

WHY MICROWAVE?

Microwave communication is a cost-effective and efficient means to connect two or more wireless points together over a variety of terrains and space, where continuous runs of cable or fiber type transmission lines would not be practical or even possible. As basic as linking two wireless locations together, or when used in a network combining a series of hops forming vast relays to link a nation, microwave driven communication is used to connect even the far reaches of space with ground-to-space and satellite-to-satellite communications. Cellular and Personal Communications Service (PCS) providers employ microwave communication for wireless inter-connects between remote tower sites and switching centers. Microwave data links provide wide bandwidths for multiple-mode transmissions equivalent to and even greater than two points linked with traditional transmission line cables. Broadband wireless systems that provide robust LAN and WAN solutions are being deployed globally due to their ease of installation, high performance and cost effectiveness.

Coverage Area

The most critical element of any microwave system is the ability to focus coverage in the most useful area. For long distance networking hops, it is the antenna's ability to efficiently focus a signal into a narrow beam. Parabolic antennas typically use a center-fed feed horn design that is similar to a flashlight. A parabolic-shaped microwave antenna is capable of signal beamwidths of less than a few degrees, which is necessary for reliable and interference free point-to-point communication. However, not all communications using microwave frequencies require such focused designs. Point-to-multipoint subscriber services and LAN/WAN networks typically require a broad service area to be illuminated. Specialized antenna designs, in the form of flat panels and tuned sector arrays, use a combination of beam steering techniques to electronically direct a wider beamwidth of microwave signals into the desired coverage area, often referred to as a sector.



Applications

With the introduction of new and affordable digital technologies, licensed and unlicensed (spread spectrum) microwave data links now serve many specialized markets, including in-building wireless LAN's, point-to-multi point internet, regional broadcast subscriber services and other new and emerging modes of personal and business communications. Broadband wireless access (BWA) is the provision of broadband, high-speed and high capacity fixed wireless data systems for Internet access, wireless local loop and other applications utilized by both home and business customers. A wide variety of frequencies are utilized for these services, including MDS/MMDS and unlicensed spread spectrum frequencies in the 2 GHz band, licensed fixed wireless spectrum in the 3.5 GHz band, UNII band frequencies in the 5 GHz band, LMDS bands at the high end of the microwave frequencies such as 38 GHz and ultra high capacity solutions at 80 GHz. These systems are deployed in either a point-to-point or point-to-multi point fashion.

Advantages

Broadband wireless access systems have several advantages over traditional wire line and fiber ring connections. They can be deployed and implemented faster than wired systems, which reduces the time required by an operator to recoup capital investments. This also allows operators to deploy these systems in a scalable or as-needed basis, and build-out to system to cover certain areas and customers as required, which reduces the upfront capital requirements. Wireless LANs, WANs and WISPs (wireless Internet service provider) are providing communities around the globe cost effective access to Internet, WLL and other data services. Over time this will help to grow the global economy and bring better lifestyles to all.

Why microwave? The wide range of wireless applications are apparent and around us every day. Operating seamlessly, quietly and unobtrusively to provide us with the widest range of instant communications for today, tomorrow and well into the future.

TYPES OF MICROWAVE ANTENNAS

Microwave Antenna Types

There are several basic “types” of microwaves antennas. Each type has certain advantages and disadvantages for particular applications in microwave and broadband wireless networks.

Grid Parabolic Antennas

At lower frequencies, below 3 Gigahertz, a parabolic reflector can be simulated by a “grid” of reflective elements. This arrangement greatly reduces wind loading on a tower or other mounting structure. Grid antennas have a lower front-to-back ratio than solid parabolic antennas. They are also limited to a single polarization. They are ideal in applications where the best performance is not required and tower and windloading are the main concern.



Standard Parabolic Antennas

Standard microwave antennas consist of a parabolic shaped reflector spun from a sheet of aluminum. The parabolic shape focuses energy at the feed point of the antenna. These parabolic antennas have a narrow focused beam of energy and relatively high gain compared to many other types of antennas. These antennas will have a mounting system to attach the antenna to a pipe, tower leg and/or a specific radio, in some cases.



High Performance Antennas

High Performance antennas are formed of aluminum, which is spun to precise tolerances. Then a shroud is also fabricated of aluminum and fitted with a planar radome to protect the feed and provide for a significant reduction in side lobes. Often manufacturers will utilize absorber material to improve the pattern performance of the side lobes and front-to-back ratio. The exception is the Discriminator™ series from Radio Waves, which utilizes a molded plastic reflector that is shaped for optimum side lobe performance.



Sector Antennas

Sector antennas are designed to provide segmented microwave coverage over a selected (sector) area; sector antennas deliver a wider beamwidth than point-to-point parabolic antennas. Sector antennas are typically used for ISM, WLL and MMDS band communications utilizing Spread Spectrum data streams for wireless connections between LAN base stations, wireless Internet, subscriber networks, PCS and other point-to-multi point communications. Antenna configurations can consist of flat panel micro strip and slot radiating designs, as well as traditional parabolic configurations. Some common horizontal beamwidths utilized include 60, 90, 120, and 180 degrees. Radio Waves sector antennas are the best performers in the industry.

Flat Panel Antennas

Radio Waves offers a complete and diverse line of flat panel antennas for point-to-point and point-to-multi point terrestrial microwave applications. These flat panel antennas are designed to be lightweight, easy to install, aligned and durable for years of reliable service. All of Radio Waves’ flat panel antennas are designed to be aesthetically pleasing and unobtrusive. These antennas are ideal for concealment in many architectural environments. Sector panel antennas for multi point networks are available in a variety of sector offerings and operating bands.



The Xcelerator® family of 5 GHz panels offer superior electrical performance.

MICROWAVE ANTENNAS: A TECHNICAL LOOK

FEED ASSEMBLIES

Feed Assemblies

A basic schematic for a microwave antenna can be seen in Figure 1. A feed system is placed with its phase center at the focus of the parabola. Ideally, all the energy radiated by the feed will be intercepted by the parabola and reflected in the desired direction. To achieve maximum gain, this energy would be distributed such that the field distribution over the aperture is uniform. However, because the feed is small, such control over the feed radiation is unattainable in practice. Some of the energy actually misses the reflecting area and is lost; this is commonly referred to as “spillover”. Also, the field is generally not uniform over the aperture, but is tapered: maximum signal at the center of the reflector, less signal at the edges. This “taper loss” reduces gain, but the field taper provides reduced side lobe levels. Optimum performance is generally considered to be achieved with a -10 dB edge illumination taper.

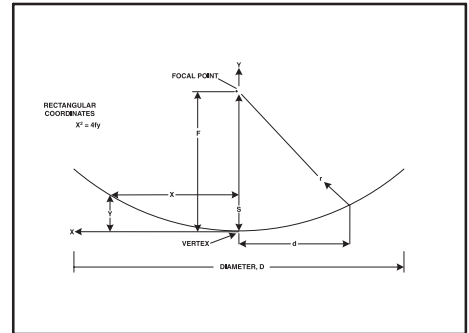

Fig. 1 Schematic of Microwave Antenna

Dipole Feed

One of the simplest feeds for a microwave antenna is the dipole. Due to its simplicity, the dipole was the first to be used as a feed for reflector antennas. While easy to design and implement, the dipole feed has inherently unequal E and H plane radiation patterns, which do not illuminate the dish effectively and thus reduce efficiency. Another disadvantage of the dipole feed for some applications is that due to unequal radiation patterns, cross-polarization performance is not optimal. Small sub-reflectors of various designs located behind the dipole will improve the feed pattern performance and gain. The dipole feed may also be utilized as feeds for non-symmetrical grid parabolas. The usage of a corner reflector behind the dipole can also enhance pattern performance and gain in many designs. The dipole feed is generally used for frequencies of less than 5 GHz.

Waveguide Feed

The open-ended waveguide is another type of simple feed. Like the dipole feed, it has inherently unequal E and H plane radiation patterns which leads to poor radiation patterns and efficiency. By flaring the waveguide opening into a horn shape, the patterns in both planes can be equalized. The flare must be gradual, such that the E and H plane phase centers are reasonably close to each other. Some designs also use circular openings, or various arrangements of “chokes” or “baffles” attached to the outside of the feed to improve performance.

Buttonhook Design

These rectangular waveguide feeds are often designed by bending a solid waveguide into a curve, such that the waveguide input is at the vertex of the dish and the feed is located at the focal point of the parabola. The “button-hook” (or J-hook) design has been a staple of commercial microwave antenna design for decades. This style of feed can provide excellent VSWR performance, which was important with older generation analog microwave radios. However, scattering off the waveguide and feed support structures causes radiation pattern distortion. Also, bending waveguide is an expensive operation requiring highly skilled labor. Special techniques must be used for dual linear or circular polarization.

Radio Waves Hybrid Design

During the 1980s the need became greater for a lower profile microwave antenna that also exhibited superior pattern performance. Two forces drove this requirement. One was the need to reduce the visual impact of radio communication installations. The other was the need to place more and more microwave “links” in the same geographic area. In 1988, Radio Waves introduced one of the first hybrid-Cassegrain sub-reflector type feeds for high frequency commercial microwave antennas. This design is a modification of the classical Cassegrain feed system.

Defining the F/D Ratio

A common way to define a parabolic dish shape is with the F/D ratio, where F is the focal length and D the diameter of the dish; the smaller the ratio, the “deeper” the dish. Most commercial microwave antennas utilize an F/D ratio of .25 to .38, with .32 to .36 being the most common. The F/D ratio for a reflector can be determined by measuring the depth of the dish, from the plane of the rim to the vertex at the center, and using the basic equation for a parabolic curve. Typically, only measurement from the vertex to the rim is required, since a parabola of revolution consists of the same shape for all radial sections.

MICROWAVE ANTENNAS: A TECHNICAL LOOK

FEED ASSEMBLIES

Cassegrain Systems

In a Cassegrain system, a feed is mounted in the dish and energy is radiated towards a sub-reflector. With a hybrid-Cassegrain system, the energy is transported through a circular waveguide that radiates into a reflective surface at the focal point. This reflected energy is then prorogated through a carefully shaped dielectric lens mounted between the sub-reflector and waveguide tube. The dielectric lens is typically made from a piece of rexolite, which has a dielectric constant of 2.54. An illustration of this feed is shown in Figure 2. At times this design is mistakenly referred to as a “back-fire” feed system. A back-fire feed does not incorporate the dielectric lens and suffers from poor side lobe performance relative to the hybrid-Cassegrain style feed.

This hybrid-Cassegrain design has several benefits over the button-hook design, including higher antenna efficiency. Since the hybrid-Cassegrain feed is shorter than the J-hook feed, the entire antenna has a lower profile and lower wind loading. The feeds use a circular waveguide that provides inherent dual-polarization capability. This is the feed system typically used at Radio Waves.

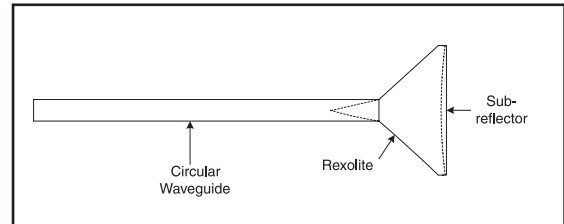

Fig. 2 Basic Outline of Hybrid Cassegrain Feed

Polarization is determined by the orientation of the input device (rectangular to circular transition or omt) that can easily be rotated to change polarization. Modern electromagnetic simulation software allows the reflecting surface of the feed to be shaped to provide superior control of radiation pattern. As these feeds are self-supporting, there is no scattering off of the feed support system as in the button-hook design. One slight disadvantage of these designs is that they have higher VSWR than button-hook feed designs. However, with today’s digital radios, this does not cause degradation in performance. These “back-fire” feeds are generally utilized for frequencies of 5 GHz to 60 GHz. For modern radio systems requiring high efficiency in a smaller package, the hybrid-Cassegrain feed reflector antenna is most applicable.

In summary, hybrid-Cassegrain feed antennas provide optimum mechanical and electrical performance for modern high frequency digital microwave radio systems. Applications that still use older analog radios requiring very stringent VSWR specifications are best served by antennas using buttonhook feed systems. Dipole feed systems can be used for applications below 6 GHz that require a low-cost antenna and do not demand the most robust pattern performance. However, for modern high frequency microwave radio systems requiring high efficiency in a smaller package, the hybrid-Cassegrain feed reflector antenna is most applicable.

Plane Polarized Feeds

The angular orientation of a microwave signal can be fixed in either a vertical or horizontal electrical plane. A plane polarized microwave feed, also known as a single polarized feed, sends and receives signals oriented in just one of two planes. A single polarized feed set in a vertical orientation will pass vertically polarized signals, while electrically suppressing any other microwave signals that are 90 degrees off plane in a horizontal orientation.

Dual Polarized Feeds

Dual Polarized feeds can detect both vertical and horizontal signal polarizations separately but simultaneously, while keeping each signal polarization isolated from the other. A dual polarized antenna system performs the same function as two separate single plane polarized antennas, reducing infrastructure costs and tower congestion. Two feed inputs are provided, one each for the vertical and horizontal polarizations.

HP and SP Feeds

Plane polarized, non-pressurized feeds are compact and completely sealed units designed to accommodate the insertion of the feed into the antenna from the back of the reflector. Polarization orientation is adjustable in either a vertical or horizontal plane. Feed input flange or connector type is dependent on the feed operating frequency. Feeds can be pressurized to 5 psi.

HPD and SPD Feeds

Dual polarized, feeds are designed for simultaneous operation in both vertical and horizontal planes. The rear-inserted feeds are sealed and watertight assemblies that feature a -30 dB cross-polarization discrimination (XPD) or better. Feed input flange or connector type is dependent upon the feed operating frequency.

MICROWAVE ANTENNAS: A TECHNICAL LOOK

ANTENNA TERMINOLOGY

Microwave Antenna Patterns

The antenna pattern is a graphical representation of the antenna's electrical performance in free space. Measured and recorded from actual test range data in two orthogonal planes such as E and H planes, and Vertical and Horizontal planes, the pattern is plotted either in rectangular or polar coordinates. A typical pattern will contain a main signal beam and several minor side lobes of radiated signal. The plotted pattern data is determined from multiple measurements taken from three frequencies - bottom, middle and top of the specified band, in both co-polar and cross polar conditions, horizontal and vertical polarizations, and recorded over the full 360 degrees of antenna's azimuth. Since an antenna pattern changes slightly with frequency, and the plotted pattern is drawn from only the highest or worst case peaks for all measured data points, actual antenna interference rejection for signal angles other than the desired main beam will often be much better than indicated in the published antenna pattern. Radio Waves antenna patterns are on file with Radio Waves, the FCC, frequency coordination houses and other government agencies throughout the world.

RPE

Radiation pattern envelopes are a common method of graphically displaying microwave antenna pattern information in a way that is easy to use for microwave system planning. RPEs represent the worst peaks in side-lobe energy and accurately represent the expected pattern performance. The RPE is composed of simple straight lines that connect all the defined peaks of energy. In fact, our antennas will often exceed the performance outlined in the RPE. At Radio Waves our highly automated and accurate manufacturing process ensures that each antenna meets your expectations as well as its RPE.

Antenna Gain

Comparing the electrical field strength of an antenna to that of a reference antenna provides a gain figure measured in dB. The gain of an antenna is a measure of how well the antenna concentrates its radiated power in a given direction. When the free-space reference is an isotropic antenna, the gain is expressed in dBi, and when the reference antenna is a half-wave dipole, the gain figure is expressed in dBd. Microwave antennas are typically specified in dBi. Antennas are usually measured at three frequencies: the bottom, middle and top of the band. Antenna gain is a measurement of how well an antenna focuses energy, and generally the higher the gain, the narrower the beamwidths.

Antenna Efficiency

When power is input to an antenna, the antenna never radiates 100% of the power. Some of the power is lost and converted into heat. Antenna efficiency is a measurement of how efficiently an antenna radiates power versus how much power is applied to the antenna. The lower distributed losses in the component of an antenna, the higher the antenna efficiency and the higher the gain for a given size.

Half Power BeamWidth (HPBW)

Half Power BeamWidth is the nominal angular width of the main beam between its -3 dB points (half power). Measured in degrees from the center of the main beam, the value is typically nominal and stated as the minimum performance value for the operating frequency band. Beamwidth typically decreases as antenna gain increases. A system's maximum beamwidth is dependent on its required coverage area, while complying with system design to keep all unnecessary signal interference to a minimum from any adjacent microwave systems.

Wavelength Speed

One can easily observe how electromagnetic energy behaves by observing light energy or by observing waves generated by a rock thrown into a pond of water. The term wavelength refers to the distance the wave travels during the time of one cycle. In free space, these electromagnetic waves travel 300 million meters per second, which we call the "speed of light." The equation for calculating this speed is $c = f \lambda$ where

C = the speed of light (3×10^8 meters per second)

f = the frequency in hertz

λ = the wavelength in meters

For high frequency systems such as microwave, frequency is commonly measured in gigahertz and wavelength is expressed in centimeters. At Radio Waves, we specialize in the design and manufacturing of innovative microwave and broadband wireless antennas from 2 to 80 GHz.

MICROWAVE ANTENNAS: A TECHNICAL LOOK

ANTENNA TERMINOLOGY

How Important is VSWR?

We sometimes receive enquires as to how important antenna feed VSWR is to large diameter microwave antennas utilized for traditional back-haul systems. In the past, most microwave radio systems utilized analog radios that required very low VSWR of 1.1:1 or better for optimum performance. New digital microwave radios do not require this low a VSWR for proper operation. While one should assure that the antenna has a VSWR of 1.5:1 to assure proper performance, there is not a requirement to try and achieve a significantly better VSWR in most cases. As an example, compare a VSWR of 1.1:1 with a VSWR of 1.3:1, which are both excellent. Two methods of comparison would be to evaluate the difference in system power loss due to the VSWR and the percentage of reflected power due to the VSWR. At a VSWR of 1.3:1, the power loss due to the reflection is .07 dB. With a VSWR of 1.1:1 the power loss is .01 dB. Thus the difference is .06 dB or 6/100 of a dB, which is an imperceptible difference.

In regards to percentage of reflected power, the antenna with a VSWR of 1.3:1 reflects 1.5% of the power and the antenna with 1 1:1 VSWR reflects .3% of the power. Thus if the input power is 1 watt the amount reflected back into the transmission line from the antenna with a VSWR of 1.3:1 is .015 watts, an amount of power that is not a factor for system performance. The difference between these two values of VSWR is not a perceptible factor in system performance and resources are better utilized reviewing factors that can optimize system performance.

VSWR

VSWR is the ratio of the maximum to minimum values of the electrical standing wave pattern along a transmission line to which a resistive load is connected. VSWR value ranges from 1 (matched load) to infinity for a short or open load. A standing wave pattern is reflected energy dissipated in heat along a transmission line, typically caused by an impedance mis-match between the load (antenna) and the transmission line. VSWR is also expressed as a Return Loss value measured in dB. Another way of expressing VSWR is return loss, which is the decibel difference between the power incident on the mismatch and the power reflected from the mismatch.

Front-to-Back Ratio (F/B)

This is a value specified in dB below the peak of the main beam, relative to a measured angular zone 180 degrees from the primary point of measurement. It is the amount of energy radiated in the rear of the antenna. Certain antennas designs, such as the HP style parabolic reflectors, will have higher front-to-back ratios than other antenna designs. F/B can be important to assure proper frequency re-use in microwave systems.

Polarization

The orientation of the electric field vector as measured from a distance from the antenna. The propagation modes of electromagnetic waves are measured in planes: Vertical, Horizontal, Circular and Elliptical. **Co-Polarization** the intended polarization for which the antenna is intended to radiate. **Cross-Polarization** the difference in dB between the peak of the co-polarized main beam and a cross-polarized signal, typically indicated as the difference between the vertical and horizontal polarization planes. The higher the value, the greater the discrimination protection from a signal of perpendicular polarization.

Isolation

The signal isolation between two ports of a device, generally stated as -dB level.

Frequency Bands

Electromagnetic waves vary in length from the very short to the very long. The microwave region is considered to be frequencies between 1 and 250 GHz (gigahertz). The wavelengths at these frequencies are 30.5 cm to 1.27 mm. For high frequency systems such as microwave, frequency is commonly measured in gigahertz, and wavelength is expressed in centimeters. At Radio Waves, we specialize in the design and manufacturing of innovative microwave and broadband wireless antennas from 2 to 80 GHz.

Beamwidth/Patterns

Narrow beamwidth reduces interference since it is less likely that surrounding RF clutter will cause interference. A larger antenna has a narrower beamwidth and thus higher gain. Larger antennas with narrower beamwidths and higher gain offer the following benefits:

- Increased strength of the transmit signal
- Increased strength of the intended receive signal
- Reduction of interference from outside the antenna's main beam.

Choosing Antenna Dish Size

When choosing the optimum size parabolic dish for your link or network, often going to a larger size dish, provides a number of key benefits. The narrower beamwidth associated with a larger diameter dish reduces interference since it is less likely that surrounding RF clutter will cause interference. Additionally the higher gain associated with a larger dish provides for improved received signal strength by increasing the level of the desired signal. When unsure, always choose the larger size dish to assure optimum link performance.

MICROWAVE ANTENNAS: A TECHNICAL LOOK

CABLE

Transmission Lines

These critical conduits guide electrical energy from one point to another. When used as a connection between the antenna and the system's radio, transmission lines work to provide a low-loss pathway between the antenna and radio for the transfer of RF signals. A microwave system's radio transceiver may be directly connected on the back of an antenna, requiring only that a VHF IF frequency be carried down to the indoor unit (IDU). Considering operating frequency, acceptable transmission line losses, power handling and even physical handling, the choice of the correct transmission line for the application can vary greatly.

Flexible Braided Coaxial Cable

Braided Coaxial Cables are used as jumper assemblies (in short lengths) for an inter-connect between an antenna feed and radio transceiver, or to carry IF signals from an ODU (outdoor unit) to an IDU (indoor unit). Jumper assemblies are available in a wide variety of lengths. They operate in frequencies below 6 GHz and in various cable diameters. Characteristic impedance is 50 ohms, with a wide variety of connector interfaces available. These cables, such as Times LMR®, can be a very cost effective transmission line system for applications such as broadband wireless as well as connecting an ODU to and IDU in high frequency point-to-point microwave systems. Due to their flexibility, these cables are ideal for in-building and in-structure applications.

Semi-Rigid Foam Dielectric Coaxial Cable

Foam Dielectric Coaxial Cable is the most commonly used cable in the cellular telecommunications industry because of its excellent electrical characteristics and reliability. Not as flexible as braided cable and slightly heavier due to a solid copper corrugated outer conductor, this type of cable may be used in long transmission line runs with proper handling and installation hardware. It is available in a variety of sizes, from 1/4-inch jumper lengths to 2-1/4" diameters. Usable operating characteristics are broadband up to approximately 6 GHz.

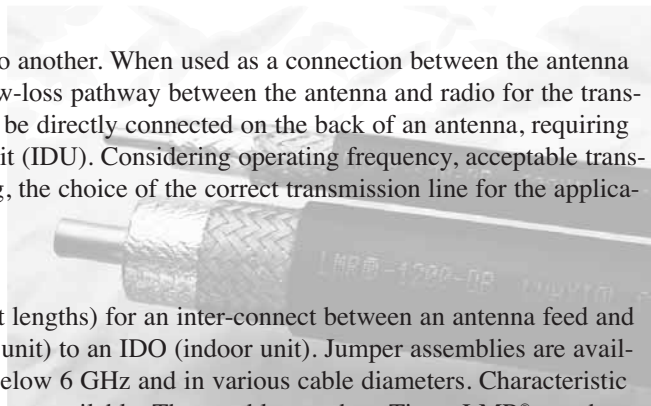
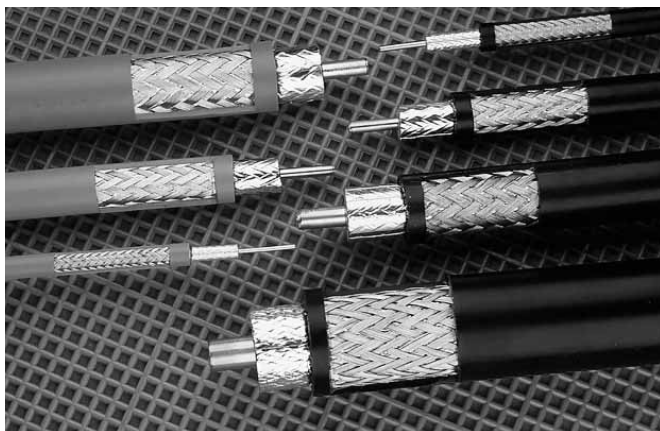

Semi-Rigid Air Dielectric Coaxial Cable

Air Dielectric Coaxial Cable is more commonly used for high power handling, such as broadcast installations. This type of cable shares the same basic cable construction as semi-rigid foam dielectric coaxial cable, but with a dielectric helix supporting the inner conductor instead of a foam dielectric. Air Dielectric runs of cable require dry air pressurization that typically consists of cylinders of nitrogen or a dry air pressurized (dehydrator) system to maintain a dry dielectric. This type of cable is suitable for long transmission runs with proper handling, and is available in a variety of sizes from 1/2 inch to over 6" diameters. Usable operating characteristics are broadband up to approximately 6 GHz.

Semi-Rigid Elliptical Waveguide

Specifically intended for microwave applications, this type of transmission line is frequency-dependent with a relatively narrow bandwidth, requiring the waveguide to be properly matched to its application to achieve a low VSWR. Elliptical waveguide is constructed from corrugated copper tube formed into an elliptical cross-section. This type of transmission line requires pressurization to prevent moisture accumulation within the waveguide. Operating frequency ranges are available up to and beyond 26 GHz.

Indoor Systems with Cable (RF Indoors)

Traditional microwave systems have all the RF equipment mounted indoors. The equipment is mounted in 19 inch or other size racks that are located in an enclosed shelter or building for environmental protection. These systems are typically for long haul microwave point-to-point systems that require high output power for these long "hops". The RF is then fed to the antenna through a run of elliptical waveguide.

MICROWAVE ANTENNAS: A TECHNICAL LOOK

ACCESSORIES & HARDWARE

Waveguide or Cable Systems

Systems utilizing waveguide or coaxial cable transmission lines require proper installation for optimum network performance. The use of adequate hangers, hoisting grips, grounding kits and weather-proofing will assure uninterrupted service in the years to come. In cases where an elliptical waveguide or air dielectric cable is to be employed, a system dry air pressurization system will need to be implemented. In these cases the proper dehydrator and transmission line pressure windows must be used for optimum results.

ODU Systems (RF Outdoors)

Outdoor Units (ODU) are remotely-mounted radio transceivers arranged in a split configuration. These units are generally found mounted on or near the antenna installation. This type of antenna/radio installation allows for rapid deployment of systems by eliminating long runs of semi-rigid foam dielectric coaxial cable or waveguide while reducing deployment costs. The signal is down-converted to an IF that is then utilized by the indoor unit (IDU). The cable carries the baseband or IF signal in addition to power and control signals. LMR® cable is ideal for these applications.

Accessory Equipment

Accessories abound to assist in the installation and mounting of antennas to buildings, roof-tops and towers. Accessories for transmission line systems, be it coaxial cable or elliptical waveguide, both require the basic installation items such as hoisting grips, hangers, grounding kits, wall/roof entries and cushioned entry boots.

Connectors

Many choices are available to mate your transmission line system to the antenna and radio. It is important that you assure the proper connectors are selected, and that for outdoor applications they are properly tightened and sealed after installation.



Grounding Kits

A properly grounded system helps reduce static due to noise, and reduces the probability of a lightning strike to your system. It is highly recommended that a minimum of three grounding kits are utilized at each installation: one at the top of the tower or vertical run, one at the bottom of the run and prior to entry in the building or shelter.

Hangers/Hoisting Grips

To ensure many years of service it is important that transmission lines are installed correctly and mounted securely. This will assure that high winds do not damage the transmission line over time.

Wall/Roof Feed-Thru

These devices allow the transmission line to be easily routed into the building or shelter, while assuring the structure is protected from moisture and other aspects of the outdoor environment.

Pressurization Systems

It is imperative that waveguide transmission line systems be protected from moisture ingress. Pressurization equipment such as pressure windows and dehydrators should be selected carefully to assure that your system is properly protected. The pressure window is usually placed in series between the bottom connector and the main waveguide feeder. This allows the RF to pass, but assures that the transmission line stays pressurized.

MICROWAVE ANTENNAS: A TECHNICAL LOOK

ANTENNA CONSTRUCTION

Microwave Antenna Construction

Microwave antennas are often deployed in very difficult environments and must be built of the highest quality materials.

Sector Antennas

Sector antennas are designed to provide segmented microwave coverage over a selected (sector) area; sector antennas deliver a wider beamwidth than point-to-point parabolic antennas. Sector antennas are typically used for ISM, WLL and MMDS band communications utilizing Spread Spectrum data streams for wireless connections between LAN base stations, wireless Internet, subscriber networks, PCS and other point-to-multipoint communications. Antenna configurations can consist of flat panel micro strip and slot radiating designs, as well as traditional parabolic configurations. Some common horizontal beamwidths utilized include 60, 90, 120, and 180 degrees.



Flat Panel Antennas

Radio Waves offers a complete and diverse line of flat panel antennas for point-to-point and point-to-multipoint terrestrial microwave applications. These flat panel antennas are designed to be light in weight, easy to install, and aligned and durable for years of reliable service. All of Radio Waves' flat panel antennas are designed to be aesthetically pleasing and unobtrusive. These antennas are ideal for concealment in many architectural environments. Sector panel antennas for multi-point networks are available in a variety of sector offerings and operating bands.



Grid Parabolic Antennas

Grid parabolic antennas from Radio Waves are constructed with aluminum tube elements that are corrosion-resistant and formed into a parabolic reflector. These grid elements are welded to both an outer rim and aluminum back structure for enhanced electrical performance and mechanical integrity. All grid tubes are manufactured with drain holes to allow condensation and rain to escape. Radio Waves' grid line of antennas are engineered and constructed to the same strict standards as our ProLine parabolic antennas. Certain pattern specifications, such as front-to-back ratio and cross-polarization, are not as stringent as with solid reflector antennas. However, grid parabolic antennas are good for when tower loading and windloading are a concern.



Standard Parabolic Antennas

Radio Waves' standard parabolic reflectors are manufactured of aluminum. Each parabola is designed with a reinforced outer edge for structural reliability. The mount is a hot-dipped galvanized steel weldment with an azimuth and elevation adjustment mechanism. These antennas are available in diameters of 1 to 8 feet for various systems and applications.



High Performance Antennas

High Performance Antennas are formed of aluminum, which is spun to precise tolerances. The parabola has an integral rim for enhanced reflector structural integrity. The shroud of a High Performance Antenna is also fabricated of aluminum and fitted with a planar radome to protect the feed. The mount is a hot-dipped galvanized steel weldment with an azimuth and elevation adjustment mechanism. The exception is the Discriminator™ series, which utilizes a molded plastic reflector that is shaped for optimum side lobe performance.



TYPICAL FREQUENCY USAGE TABLE AND VSWR TO RETURN LOSS CONVERSION CHART

Typical Frequency Usage Table

Band	Frequency Range	Typical Usage
2 GHz	2.4-2.7 GHz	Unlicensed Spread Spectrum
3 GHz	3.4-3.6 GHz	Fixed Wireless Access
4 GHz	3.8-4.2 GHz	Typically public operator band
5 GHz	5.25-5.85 GHz	Unlicensed Spread Spectrum
6 GHz	5.9-7.1 GHz	Long haul medium to high capacity
7/8 GHz	7.1-8.5 GHz	Long haul medium to high capacity
10 GHz	10.7-11.7 GHz	Typically public operator band
13 GHz	12.7-13.25 GHz	Typically low to medium capacity
15 GHz	14.25-15.35 GHz	Various capacities
18 GHz	17.7-19.7 GHz	Low to medium capacity
23 GHz	21.2-23.6 GHz	All capacities
24 GHz	24.25-26.5 GHz	All capacities, PTMP
38 GHz	37-40 GHz	Various capacities
60 GHz	56-64 GHz	Various capacities
80 GHz	71-86 GHz	Short haul, ultra high capacity

VSWR to Return Loss Conversion Chart

VSWR	R.L. (dB)	VSWR	R.L. (dB)	VSWR	R.L. (dB)
1.00	Infinite	1.17	22.1	1.50	14.0
1.01	46.0	1.18	21.7	1.55	13.3
1.02	40.1	1.19	21.2	1.60	12.7
1.03	36.6	1.20	20.8	1.65	12.2
1.04	34.2	1.21	20.4	1.70	11.7
1.05	32.3	1.22	20.1	1.75	11.3
1.06	30.7	1.23	19.7	1.80	10.9
1.07	29.4	1.24	19.4	1.85	10.5
1.08	28.3	1.25	19.1	1.90	10.2
1.09	27.3	1.26	18.8	1.95	10.0
1.10	26.5	1.27	18.5	2.00	9.5
1.11	25.7	1.28	18.2	2.10	8.9
1.12	24.9	1.29	17.9	2.20	8.5
1.13	24.3	1.30	17.7	2.30	8.1
1.14	23.7	1.35	16.5	2.40	7.7
1.15	23.1	1.40	15.6	2.50	7.4
1.16	22.6	1.45	14.7	3.00	6.0

POWER CONVERSION TABLE

Power Conversion Table

dBm	watts	dBm	watts	dBm	watts	dBm	watts
27.0	501 mw	33.0	2.00	39.0	7.94	45.2	33.11
27.2	525 mw	33.2	2.09	39.2	8.32	45.4	34.67
27.4	550 mw	33.4	2.19	39.4	8.71	45.6	36.31
27.6	575 mw	33.6	2.29	39.6	9.12	45.8	38.02
27.8	603 mw	33.8	2.40	39.8	9.55	46.0	39.81
28.0	631 mw	34.0	2.51	40.0	10.00	46.2	41.69
28.2	661 mw	34.2	2.63	40.2	10.47	46.4	43.65
28.4	692 mw	34.4	2.75	40.4	10.96	46.8	47.86
28.6	724 mw	34.6	2.88	40.6	11.48	47.0	50.12
28.8	759 mw	34.8	3.02	40.8	12.02	47.2	52.48
29.0	794 mw	35.0	3.16	41.0	12.59	47.4	54.95
29.2	832 mw	35.2	3.31	41.2	13.18	47.6	57.54
29.4	871 mw	35.4	3.47	41.4	13.80	47.8	60.26
29.6	912 mw	35.6	3.63	41.6	14.45	48.0	63.10
29.8	955 mw	35.8	3.80	41.8	15.14	48.2	66.07
30.0	1.00	36.0	3.98	42.0	15.85	48.4	69.18
30.2	1.05	36.2	4.17	42.2	16.60	48.6	72.44
30.4	1.10	36.4	4.37	42.4	17.38	48.8	75.86
30.6	1.15	36.6	4.57	42.6	18.20	49.0	79.43
30.8	1.20	36.8	4.79	42.8	19.05	49.2	83.18
31.0	1.26	37.0	5.01	43.0	19.95	49.4	87.10
31.2	1.32	37.2	5.25	43.2	20.89	49.6	91.20
31.4	1.38	37.4	5.50	43.4	21.88	49.8	95.50
31.6	1.45	37.6	5.75	43.6	22.91	50.0	100.00
31.8	1.51	37.8	6.03	43.8	23.99	55.0	316.00
32.0	1.58	38.0	6.31	44.0	25.12	56.0	398.00
32.2	1.66	38.2	6.61	44.2	26.30	57.0	501.00
32.4	1.74	38.4	6.92	44.6	28.84	58.0	631.00
32.6	1.82	38.6	7.24	44.8	30.20	59.0	794.00
32.8	1.91	38.8	7.59	45.0	31.62	60.0	1000.00

RECTANGULAR WAVEGUIDE REFERENCE TABLE

EIA WG WR () MDL Band	JAN WG RG ()	Recommended Operating Range for TE ₁₀ Mode		Cut-off for TE ₁₀ Mode			Theoretical cw power rating lowest to highest frequency (neg. watt)	Theoretical Attenuation lowest to highest frequency (dB/100 ft)	Material Alloy	JAN FLANGE	DIMENSIONS (Inches)				
		Frequency GHz	Wavelength (cm)	Frequency GHz	Wavelength (cm)	Range in λ _g					Choke UG ()/U Cover UG ()/U	Inside	Tol. ±	Outside	Tol. ±
2300	290	0.32-0.49	93.68-61.18	0.256	116.84	1.68-1.17	153.0-212.0	.051-.031	Alum.	--	23.125-11.625	0.020	23.250-11.750	.020	0.125
2100	291	0.35-0.53	86.56-56.56	0.281	106.68	1.68-1.18	120.0-173.0	.054-.034	Alum.	--	21.125-10.625	0.020	21.250-10.750	.020	0.125
1800	201	0.41-0.625	73.11-47.96	0.328	91.44	1.67-1.18	93.4-131.9	.056-.038	Alum.	--	18.000-9.000	0.020	18.250-9.250	.020	0.125
1500	202	0.49-0.75	61.18-39.97	0.393	76.20	1.62-1.17	67.6-93.3	.069-.050	Alum.	--	15.000-7.500	0.015	15.250-7.750	.015	0.125
1150	203	0.64-0.96	46.84-31.23	0.513	58.42	1.82-1.18	35.0-53.8	.128-.075	Alum.	--	11.500-5.750	0.015	11.750-6.000	.015	0.125
975	204	0.75-1.12	39.95-26.76	0.605	49.53	1.70-1.19	27.0-38.5	.137-.095	Alum.	--	9.750-4.875	0.010	10.000-5.125	.010	0.125
770	205	0.96-1.45	31.23-20.67	0.766	39.12	1.66-1.18	17.2-24.1	.201-.136	Alum.	--	7.700-3.850	0.010	7.950-4.100	.010	0.125
650	69 103	1.12-1.70	26.76-17.63	0.908	33.02	1.70-1.18	11.9-17.2	.317-.312 .269-.178	Brass Alum.	417A 418A	6.500-3.250	0.010	6.660-3.410	.010	0.080
510	--	1.45-2.20	20.67-13.62	1.157	25.91	1.67-1.18	7.5-10.7	--	--	--	5.100-2.550	0.010	5.260-2.710	.010	0.080
430 W	104 105	1.70-2.60	17.63-11.53	1.372	21.84	1.70-1.18	5.2-7.5	.588-.385 .501-.330	Brass Alum.	435A 437A	4.300-2.150	0.008	4.460-2.310	.008	0.080
340	112 113	2.20-3.30	13.63-9.08	1.736	17.27	1.78-1.22	3.1-4.5	.877-.572 .751-.492	Brass Alum.	553 554	3.400-1.700	0.005	3.560-1.860	.005	0.080
284 S	48 75	2.60-3.95	11.53-7.59	2.078	14.43	1.67-1.17	2.2-3.2	1.102-.752 .940-.641	Brass Alum.	54B 53 585A 584	2.840-1.340	0.005	3.000-1.500	.005	0.080
229	--	3.30-4.90	9.08-6.12	2.577	11.63	1.62-1.17	1.6-2.2	--	--	--	2.290-1.145	0.005	2.418-1.273	.005	0.064
187 C	49 95	3.95-5.85	7.59-5.12	3.152	9.510	1.67-1.19	1.4-2.0	2.08-.144 1.77-1.12	Brass Alum.	148C 149A 406B 407	1.872-0.872	0.005	2.000-1.000	.005	0.064
159	--	4.90-7.05	6.12-4.25	3.711	0.078	1.52-1.19	0.79-1.0	--	--	--	1.590-0.795	0.004	1.718-0.923	.004	0.064
137	50 106	5.85-8.20	5.12-3.66	4.301	6.970	1.48-1.17	0.56-0.71	2.87-2.30 2.45-1.94	Brass Alum.	343B 344 440B 441	1.372-0.622	0.004	1.500-0.750	.004	0.064
112 X _L	54 68	7.05-10.0	4.25-2.99	5.259	5.700	1.51-1.17	0.35-0.46	2.12-3.21 2.50-2.74	Brass Alum.	52B 51 137B 138	1.122-0.497	0.004	1.250-0.625	.004	0.064
90 X	52 67	8.20-12.40	3.66-2.42	6.557	4.572	1.68-1.18	0.20-0.29	6.45-4.48 5.49-3.83	Brass Alum.	40B 39 136B 135	0.900-0.400	0.003	1.000-0.500	.003	0.050
75	--	10.00-15.00	2.99-2.00	7.868	3.810	1.64-1.17	0.17-0.23	--	--	--	0.750-0.375	0.003	0.850-0.475	.003	0.050
62 Ku	91 107	12.4-18.0	2.42-1.66	9.486	3.160	1.55-1.18	0.12-0.16	9.51-8.31 6.14-5.36	Brass Silver	541A 419 --	0.622-0.311	0.002	0.702-0.391	.003	0.040
51	--	15.00-22.00	2.00-1.36	11.574	2.590	1.58-1.18	0.080-0.107	--	--	--	0.510-0.255	0.0025	0.590-0.335	.003	0.040
42 K	53 12 66	18.00-26.50	1.66-1.13	14.047	2.134	1.60-1.18	0.043-0.058	27.7-19.8 17.6-12.6 13.3-9.5	Brass Alum. Silver	596A 595 -- 598 597	0.420-0.170	0.0020	0.500-0.250	.003	0.040
34	--	22.00-33.00	1.36-0.91	17.328	1.730	1.62-1.18	0.034-0.048	--	Brass	-- 1530	0.340-0.170	0.0020	0.420-0.250	.003	0.040
28 K _A	96	26.50-40.00	1.13-0.75	21.081	1.422	1.65-1.17	0.022-0.031	21.9-15.0	Silver	600A 599	0.280-0.140	0.0015	0.360-0.220	.002	0.040
22 Q	97	33.00-50.00	0.91-0.60	26.342	1.138	1.67-1.17	0.014-0.020	31.0-20.9	Silver	-- 383	0.224-0.112	0.0010	0.304-0.192	.002	0.040
19	--	40.00-60.00	0.75-0.50	31.357	0.956	1.63-1.16	0.011-0.015	--	Brass	-- 1529	0.188-0.094	0.0010	0.268-0.174	.002	0.040
15 V	98	50.00-75.00	0.60-0.40	39.863	0.752	1.67-1.17	0.0063-0.0090	52.9-39.1	Silver	-- 385	0.148-0.074	0.0010	0.228-0.154	.002	0.040
12	99	60.00-90.00	0.50-0.33	48.350	0.620	1.68-1.18	0.0042-0.0060	93.3-52.2	Silver	-- 387	0.122-0.061	0.0005	0.202-0.141	.002	0.040
10	--	75.00-110.0	0.40-0.27	59.010	0.508	1.61-1.18	0.0030-0.0041	--	Silver	-- 1528	0.100-0.050	0.0005	0.180-0.130	.002	0.040

FOCAL LENGTH TO DIAMETER RATIO VS. ANGULAR APERTURE FOR PARABOLIC REFLECTORS

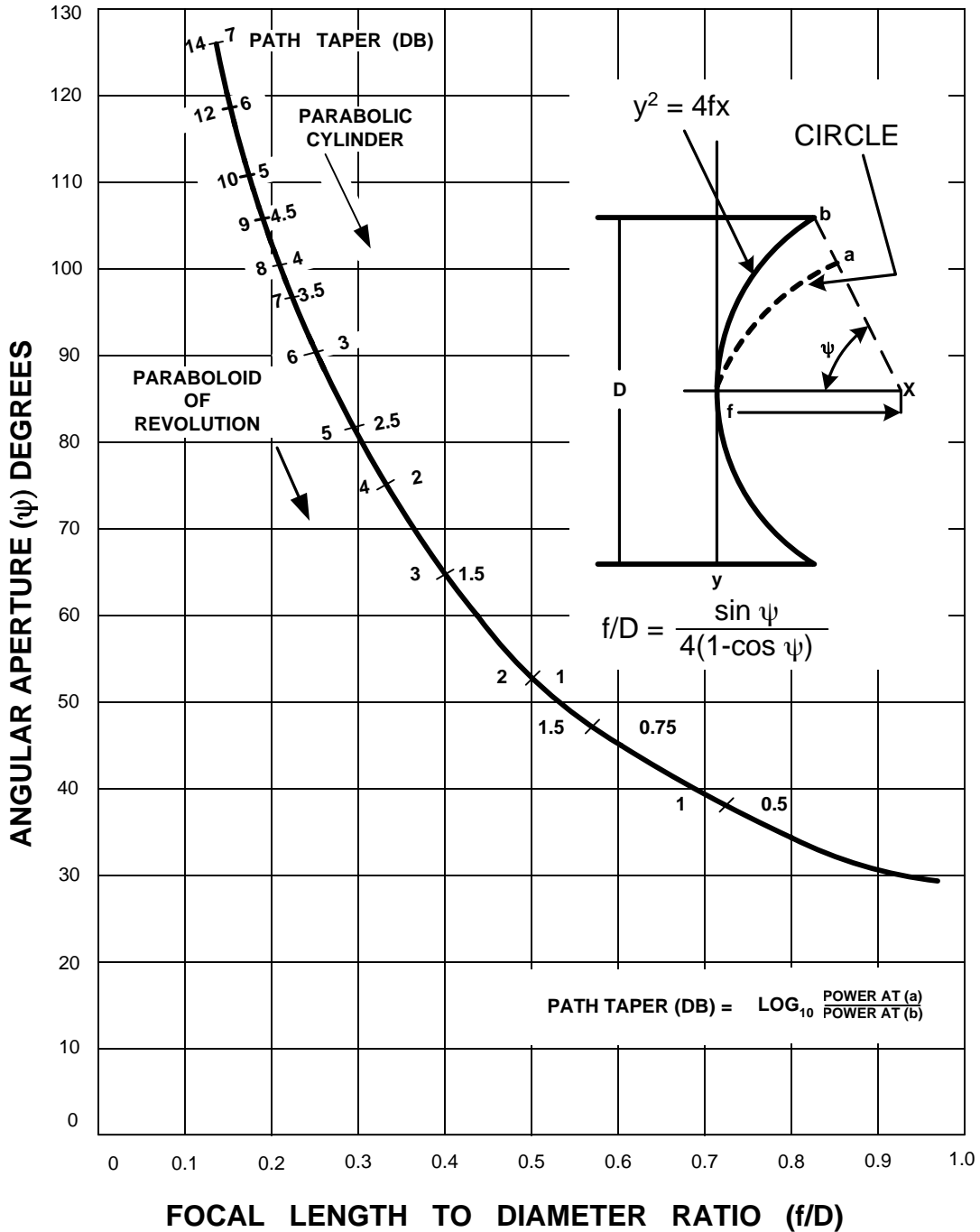

RADIO WAVES BROADBAND FIXED WIRELESS PRODUCTS

Radio Waves' line of broadband fixed wireless antennas are designed to deliver optimum performance for use with ISM, Wi-Fi, MMDS, WCS, UNII and WLL point-to-point and point-to-multi point systems. Four types of antennas comprise this product line. Sector antennas are used in base stations of PtMP systems. Flat panels can be deployed for PtMP subscribers or utilized for PtP systems requiring less visible antennas. Grid antennas are used in high gain backhaul applications, and the Radio Waves SP series of solid parabolic antennas are the industry's choice for a high quality PtP antenna solution. All of these antennas are designed and manufactured by Radio Waves for superior performance and years of dependable service.

Sector Antennas

Radio Waves offers the widest selection of sector antennas in the industry for point-to-multi-point base station applications. Models are available in the 2.4, 3.5, & 5.8 GHz frequency bands. A variety of beamwidths can be selected, including 60, 90, 120 or 180 degrees. These antennas offer a lightweight and rugged design, and are built for years of trouble-free service. Vertical or horizontal polarization models may be chosen. These antennas include all mounting hardware and can be attached to a 1.75" - 4.0" diameter pipe mast.



Grid Antennas

Radio Waves' G-Series parabolic grid antennas feature a lightweight and rugged design for applications that require high gain with a low wind-load. These heavy-duty grids are available in 3 ft, 4 ft and 6 ft diameters, in the unlicensed 2.4-2.5 GHz band. Offering 40% lower windloads than solid parabolic antennas of the same diameter, these grids are an excellent choice for high wind backhaul applications that don't require stringent pattern performance.



Flat Panel & Xcelerator® Antennas

Low profile flat panel antennas offer superior performance in a small and aesthetically pleasing package. These antennas are plane polarized. The polarization can be changed from vertical to horizontal by simply rotating the antenna 90 degrees on its mount. These flat panels are available in the 4 and 5 GHz frequency bands. The standard mount accommodates a 1" - 2.5" pipe mast, while allowing for +/- 25 degrees of elevation adjustment.



Standard Parabolic Antennas

The SP-Series of standard performance parabolic antennas from Radio Waves are available in 1 ft through 8 ft diameters. These antennas are spun aluminum reflectors with interchangeable feeds that cover the 2.4, 3.5, and 5.2/5.8 GHz frequency bands. The 1 and 2 Ft. antennas are supplied with a mount that can be attached to a 2" - 4.5" pipe mast and features fine adjustments of both azimuth and elevation. The 3 - 8 Ft. antennas can be attached to a 4.5" pipe mast and features fine adjustments of both azimuth and elevation. Optional radomes are available for reduced windloading. Dual polarized and dual band models are also available.



High Performance Antennas

The HP-Series are also available for applications that require superior pattern performance to reduce interference potential.

SECTOR ANTENNAS: DIMENSIONS AND ELECTRICAL SPECIFICATIONS

40° SECTOR ANTENNAS, SEC SERIES

ANTENNA DIMENSIONS FOR ALL GHZ RANGES:

Small Package 25.5 x 8.5 x 4.0" (65 x 21.6 x 10cm) 5 lbs. (2.3kg)
14, 17 and 18 dBi models

Large Package 41.5 x 8.5 x 4.0" (105 x 21.6 x 10cm) 7 lbs. (3.2kg)
Dual Polarization models, SEC-25V(or H)-60-17 models

ELECTRICAL SPECIFICATIONS (typical performance)

Model Number	Frequency, GHz	Polarization	Gain dBi (nominal)	Beamwidth-3dB Az° El.°	X-Pol. Rej.,dB	F/B Ratio dB	VSWR, Max (R.L., dB)	Optional Downtilt
SEC-35V-40-18	3.40 - 3.60	Vertical	18.0	40 8	25	>30	1.47:1 (14.4)	STD-15-1
SEC-35H-40-18	3.40 - 3.60	Horizontal	17.5	40 8	25	>30	1.47:1 (14.4)	STD-15-2

60° SECTOR ANTENNAS, SEC SERIES

ELECTRICAL SPECIFICATIONS (typical performance) For 2.15 - 2.70 GHz models, contact the factory.

Model Number	Frequency, GHz	Polarization	Gain dBi (nominal)	Beamwidth-3dB Az° El.°	X-Pol. Rej.,dB	F/B Ratio dB	VSWR, Max (R.L., dB)	Optional Downtilt
2.4-2.7 GHz Range								
SEC-25V-60-14	2.40 - 2.70	Vertical	14.5	60 16	25	>25	1.5:1 (14.0)	STD-15-1
SEC-25H-60-14	2.40 - 2.70	Horizontal	14.5	60 16	25	>25	1.5:1 (14.0)	STD-15-1
SEC-25D-60-14	2.40 - 2.70	Dual	14.5	60 16	25	>25	1.5:1 (14.0)	STD-15-2
SEC-25V-60-17	2.40 - 2.70	Vertical	17.5	60 8	25	>25	1.5:1 (14.0)	STD-15-2
SEC-25H-60-17	2.40 - 2.70	Horizontal	17.5	60 8	25	>25	1.5:1 (14.0)	STD-15-2
SEC-2V-5H-60*	2.40 - 2.50	Vertical	14.0	60 16	20	25	1.5:1 (14.0)	STD-15-2
	5.725 - 5.85	Horizontal	17.5	60 8	20	35	1.5:1 (14.0)	STD-15-2
SEC-2H-5V-60*	2.40 - 2.50	Horizontal	14.0	60 16	20	25	1.5:1 (14.0)	STD-15-2
	5.725 - 5.85	Vertical	17.5	60 8	20	35	1.5:1 (14.0)	STD-15-2
3.4-3.6 GHz Range								
SEC-35V-60-17	3.4 - 3.6	Vertical	17.5	60 8	25	30	1.5:1 (14.0)	STD-15-1
SEC-35H-60-17	3.4 - 3.6	Horizontal	17.5	60 8	25	30	1.5:1 (14.0)	STD-15-1
SEC-35D-60-17*	3.4 - 3.6	Dual	17.5	60 8	25	30	1.5:1 (14.0)	STD-15-2
4.4 - 5.0 GHz Range								
SEC-47V-60-17	4.4 - 5.0	Vertical	17.0	60 8	25	35	1.5:1 (14.0)	STD-15-1
SEC-47H-60-17	4.4 - 5.0	Horizontal	17.0	60 8	25	35	1.5:1 (14.0)	STD-15-1
5.25 - 5.85 GHz Range								
SEC-55V-60-17	5.250 - 5.850	Vertical	17.0	60 8	25	>35	1.5:1 (14.0)	STD-15-1
SEC-55H-60-17	5.250 - 5.850	Horizontal	17.0	60 8	25	>35	1.5:1 (14.0)	STD-15-1
SEC-55D-60-17	5.250 - 5.850	Dual	17.0	60 8	25	>35	1.5:1 (14.0)	STD-15-2
SEC-5V-60-18*	5.725 - 5.850	Vertical	18.0	60 6	25	>35	1.5:1 (14.0)	STD-15-1

All specifications subject to change without notice.

*Consult factory for availability

SECTOR ANTENNAS: DIMENSIONS AND ELECTRICAL SPECIFICATIONS

90° SECTOR ANTENNAS, SEC SERIES

ANTENNA DIMENSIONS FOR ALL GHz RANGES:

Small Package 25.5 x 8.5 x 4.0" (65 x 21.6 x 10cm) 5 lbs. (2.3kg)
14 & 17 dBi models

Large Package 41.5 x 8.5 x 4.0" (105 x 21.6 x 10cm) 7 lbs. (3.2kg)
Dual Polarization models, SEC-25V(or H)-90-16 models

ELECTRICAL SPECIFICATIONS (typical performance) For 2.15 - 2.70 GHz models, contact the factory.

Model Number	Frequency, GHz	Polarization	Gain dBi (nominal)	Beamwidth-3dB Az° El.°	X-Pol. Rej.,dB	F/B Ratio dB	VSWR, Max (R.L., dB)	Optional Downtilt
2.4-2.7 GHz & Dual Band Range								
SEC-25V-90-13	2.40 - 2.70	Vertical	13.0	90 16	25	>25	1.5:1 (14.0)	STD-15-1
SEC-25H-90-13	2.40 - 2.70	Horizontal	13.0	90 16	25	>25	1.5:1 (14.0)	STD-15-1
SEC-25D-90-13	2.40 - 2.70	Dual	13.0	90 16	25	>25	1.5:1 (14.0)	STD-15-2
SEC-25V-90-16	2.40 - 2.70	Vertical	16.0	90 8	25	>25	1.5:1 (14.0)	STD-15-2
SEC-25H-90-16	2.40 - 2.70	Horizontal	16.0	90 8	25	>25	1.5:1 (14.0)	STD-15-2
SEC-25H-90-16HP*	2.40 - 2.70	Horizontal	16.0	90 8	25	35	1.5:1 (14.0)	STD-15-2
SEC-2V-5H-90*	2.40 - 2.50	Vertical	13.0	90 16	20	25	1.5:1 (14.0)	STD-15-2
	5.725 - 5.85	Horizontal	16.0	90 8	20	35	1.5:1 (14.0)	STD-15-2
SEC-2H-5V-90*	2.40 - 2.50	Horizontal	13.0	90 16	20	25	1.5:1 (14.0)	STD-15-2
	5.725 - 5.85	Vertical	16.0	90 8	20	35	1.5:1 (14.0)	STD-15-2
3.4-3.6 GHz Range								
SEC-35V-90-16	3.4 - 3.6	Vertical	16.0	90 8	25	30	1.5:1 (14.0)	STD-15-1
SEC-35H-90-16	3.4 - 3.6	Horizontal	16.0	90 8	25	30	1.5:1 (14.0)	STD-15-1
SEC-35D-90-16	3.4 - 3.6	Dual	16.0	90 8	25	30	1.5:1 (14.0)	STD-15-2
SEC-35H-90-16HP*	3.4 - 3.6	Horizontal	16.0	90 8	25	>35	1.5:1 (14.0)	STD-15-1
SEC-35V-90-16HP*	3.4 - 3.6	Vertical	16.0	90 8	25	>35	1.5:1 (14.0)	STD-15-1
SEC-35D-90-16HP*	3.4 - 3.6	Dual	16.0	90 8	25	>35	1.5:1 (14.0)	STD-15-2
4.4 - 5.0 GHz Range								
SEC-47V-90-16	4.4 - 5.0	Vertical	16.0	90 8	25	30	1.5:1 (14.0)	STD-15-1
SEC-47H-90-16	4.4 - 5.0	Horizontal	16.0	90 8	25	30	1.5:1 (14.0)	STD-15-1
5.25 - 5.85 GHz Range								
SEC-55V-90-16	5.25 - 5.85	Vertical	16.0	90 8	25	>35	1.5:1 (14.0)	STD-15-1
SEC-55H-90-16	5.25 - 5.85	Horizontal	16.0	90 8	25	>35	1.5:1 (14.0)	STD-15-1
SEC-55D-90-16	5.25 - 5.85	Dual	16.0	90 8	25	>35	1.5:1 (14.0)	STD-15-2
SEC-55H-90-16HP*	5.25 - 5.85	Horizontal	16.0	90 8	25	>35	1.5:1 (14.0)	STD-15-1
SEC-55V-90-16HP*	5.25 - 5.85	Vertical	16.0	90 8	25	>35	1.5:1 (14.0)	STD-15-1
SEC-55D-90-16HP*	5.25 - 5.85	Dual	16.0	90 8	25	>35	1.5:1 (14.0)	STD-15-2
5.725 - 5.85 GHz Range								
SEC-5V-90-17*	5.725 - 5.85	Vertical	17.0	90 6	25	35	1.5:1 (14.0)	STD-15-1
SEC-5H-90-17*	5.725 - 5.85	Horizontal	17.0	90 6	25	35	1.5:1 (14.0)	STD-15-1

All specifications subject to change without notice.

*Consult factory for availability. HP series of sectors is a unique design offering improved F/B ratio.

SECTOR ANTENNAS: DIMENSIONS AND ELECTRICAL SPECIFICATIONS

120° SECTOR ANTENNAS, SEC SERIES

ANTENNA DIMENSIONS FOR ALL GHz RANGES:

SEC-25V-120-11	25.5 x 8.5 x 4.0" (65 x 21.6 x 10cm)	5 lbs. (2.3kg)
SEC-25V-120-14	41.5 x 8.5 x 4.0" (105 x 21.6 x 10cm)	7 lbs. (3.2kg)
SEC-35V-120-11	25.5 x 8.5 x 4.0" (65 x 21.6 x 10cm)	5 lbs. (2.3kg)
SEC-35V-120-14	25.5 x 8.5 x 4.0" (65 x 21.6 x 10cm)	5 lbs. (2.3kg)
SEC-35H-120-14	25.5 x 8.5 x 4.0" (65 x 21.6 x 10cm)	5 lbs. (2.3kg)
SEC-5V-120-14 (Tube)	3.0" x 16.5" (7.6 x 41.9cm)	5 lbs. (2.3kg)
SEC-5V-120-16 (Tube)	3.0" x 22.5" (7.6 x 57.2cm)	7 lbs. (3.2kg)
OMNH-5-8 (Tube)	30" x 1.75" (76.2 x 4.45cm)	5 lbs. (2.3kg)

ELECTRICAL SPECIFICATIONS (typical performance)

2.4-2.7 GHz RANGE

Model Number	Frequency, GHz	Polarization	Gain dBi (nominal)	Beamwidth-3dB Az°	El.°	X-Pol. Rej., dB	F/B Ratio dB	VSWR, Max (R.L., dB)	Optional Downtilt
SEC-25V-120-11	2.40 - 2.70	Vertical	11.0	120	16	25	>25	1.5:1 (14.0)	STD-15-1
SEC-25V-120-14	2.40 - 2.70	Vertical	14.0	120	8	25	>25	1.5:1 (14.0)	STD-15-2

3.5 GHz RANGE

Model Number	Frequency, GHz	Polarization	Gain dBi (nominal)	Beamwidth-3dB Az°	El.°	X-Pol. Rej., dB	F/B Ratio dB	VSWR, Max (R.L., dB)	Optional Downtilt
SEC-35V-120-11	3.40 - 3.60	Vertical	11.0	120	16	25	>25	1.5:1 (14.0)	STD-15-1
SEC-35V-120-14	3.40 - 3.60	Vertical	14.0	120	8	25	>25	1.5:1 (14.0)	STD-15-2
SEC-35H-120-14	3.40 - 3.60	Horizontal	14.0	120	8	25	>25	1.5:1 (14.0)	STD-15-2

5.725-5.85 GHz RANGE

Model Number	Frequency, GHz	Polarization	Gain dBi (nominal)	Beamwidth-3dB Az°	El.°	X-Pol. Rej., dB	F/B Ratio dB	VSWR, Max (R.L., dB)	Optional Downtilt
SEC-5V-120-14	5.725-5.850	Vertical	14.0	120	8	25	>25	1.5:1 (14.0)	DT Included
SEC-5V-120-16	5.725-5.850	Vertical	16.0	120	4	25	>25	1.5:1 (14.0)	DT Included

All specifications subject to change without notice

180° SECTOR ANTENNAS, SEC SERIES

ANTENNA DIMENSIONS FOR 2.5 GHz:

SEC-25V-180-10	25.5 x 8.5 x 4.0" (65 x 21.6 x 10cm)	5 lbs. (2.3kg)
SEC-25V-180-13	41.5 x 8.5 x 4.0" (105 x 21.6 x 10cm)	7 lbs. (3.2kg)

ELECTRICAL SPECIFICATIONS (typical performance)

2.4-2.7 GHz RANGE

Model Number	Frequency, GHz	Polarization	Gain dBi (nominal)	Beamwidth-3dB Az°	El.°	X-Pol. Rej., dB	F/B Ratio dB	VSWR, Max (R.L., dB)	Optional Downtilt
SEC-25V-180-10	2.40-2.70	Vertical	10.0	180	16	20	20	1.5:1 (14.0)	STD-15-1
SEC-25V-180-13	2.40-2.70	Vertical	13.0	180	8	20	20	1.5:1 (14.0)	STD-15-2

All specifications subject to change without notice

PRO-VIDER SERIES SECTOR ANTENNAS: DIMENSIONS AND ELECTRICAL SPECIFICATIONS:

OMNI ANTENNA, OMN SERIES

Model Number	Frequency, GHz	Polarization	Gain dBi (nominal)	Beamwidth -3dB		X-Pol. Rejection, dB	VSWR, Max (R.L., dB)
				Az°	El.°		
OMNH-5-8	5.725-5.85	Horizontal	8.0	360	14	-30	1.7:1 (12.0)
OMNV-4.7-5	4.4-5.0	Vertical	5.0	360	24	-30	1.5:1 (-14)
OMNV-4.7-10	4.4-5.0	Vertical	10.5	360	6	-30	1.5:1 (-14)
OMNV-4.9-5.0	4.9-5.0	Vertical	9.5	360	11	-30	1.5:1 (-14)
OMNH-4.9-5.0	4.9-5.0	Horizontal	9	360	7	-30	1.5:1 (-14)

Consult factory for availability

60° PRO-VIDER SERIES ANTENNAS, PRO SERIES

ANTENNA DIMENSIONS FOR ALL GHz RANGES:

PRO-24V-60-14	25.5 x 8.5 x 4.0" (65 x 21.6 x 10cm)	5 lbs. (2.3kg)
PRO-24H-60-14	25.5 x 8.5 x 4.0" (65 x 21.6 x 10cm)	5 lbs. (2.3kg)
PRO-24V-60-17	41.5 x 8.5 x 4.0" (105 x 21.6 x 10cm)	7 lbs. (3.2kg)
PRO-24H-60-17	41.5 x 8.5 x 4.0" (105 x 21.6 x 10cm)	7 lbs. (3.2kg)

ELECTRICAL SPECIFICATIONS (typical performance)

2.4-2.5 GHz RANGE

Model Number	Frequency, GHz	Polarization	Gain dBi (nominal)	Beamwidth -3dB		X-Pol. Rej., dB	F/B Ratio dB	VSWR, Max (R.L., dB)	Optional Downtilt
PRO-24V-60-14	2.40-2.50	Vertical	14.5	60	16	20	>25	1.7:1 (12.0)	STD-15-1
PRO-24H-60-14	2.40-2.50	Horizontal	14.5	60	16	20	>25	1.7:1 (12.0)	STD-15-1
PRO-24V-60-17	2.40-2.50	Vertical	17.5	60	8	20	>25	1.7:1 (12.0)	STD-15-2
PRO-24H-60-17	2.40-2.50	Horizontal	17.5	60	8	20	>25	1.7:1 (12.0)	STD-15-2

All specifications subject to change without notice

90° PRO-VIDER SERIES ANTENNAS, PRO SERIES

ANTENNA DIMENSIONS FOR ALL GHz RANGES:

PRO-24V-90-13	25.5 x 8.5 x 4.0" (65 x 21.6 x 10cm)	5 lbs. (2.3kg)
PRO-24H-90-13	25.5 x 8.5 x 4.0" (65 x 21.6 x 10cm)	5 lbs. (2.3kg)
PRO-24V-90-16	41.5 x 8.5 x 4.0" (105 x 21.6 x 10cm)	7 lbs. (3.2kg)
PRO-24H-90-16	41.5 x 8.5 x 4.0" (105 x 21.6 x 10cm)	7 lbs. (3.2kg)

ELECTRICAL SPECIFICATIONS (typical performance)

2.4-2.5 GHz RANGE

Model Number	Frequency, GHz	Polarization	Gain dBi (nominal)	Beamwidth -3dB		X-Pol. Rej., dB	F/B Ratio dB	VSWR, Max (R.L., dB)	Optional Downtilt
PRO-24V-90-13	2.40-2.50	Vertical	13.0	90	16	20	>25	1.7:1 (12.0)	STD-15-1
PRO-24H-90-13	2.40-2.50	Horizontal	13.0	90	16	20	>25	1.7:1 (12.0)	STD-15-1
PRO-24V-90-16	2.40-2.50	Vertical	16.0	90	8	20	>25	1.7:1 (12.0)	STD-15-2
PRO-24H-90-16	2.40-2.50	Horizontal	16.0	90	8	20	>25	1.7:1 (12.0)	STD-15-2

All specifications subject to change without notice

STANDARD PARABOLIC ANTENNAS: DIAMETERS, WEIGHTS AND ELECTRICAL SPECIFICATIONS

STANDARD PARABOLIC ANTENNAS, SP SERIES - PLANE POLARIZED

ANTENNA DIAMETERS AND WEIGHTS:

1 ft	(0.3m)	- 15 lbs. (6.8 kg)
2 ft	(0.6m)	- 22 lbs. (9.9 kg)
3 ft	(0.9m)	- 35 lbs. (15.8 kg)
4 ft	(1.2m)	- 60 lbs. (27.0 kg)
6 ft	(1.8m)	- 90 lbs. (40.5 kg)
8 ft	(2.4m)	- 250 lbs. (112.5 kg)

ELECTRICAL SPECIFICATIONS (typical performance)

Model Number	Frequency, GHz	Polarization	Gain dBi (nominal)	Beamwidth -3dB	X-Pol. Rejection, dB	F/B Ratio dB	VSWR, Max (R.L., dB)
1.3 - 1.5 GHz Range							
SP2-1.3	1.35 - 1.535	Plane	15.8	25.0	20	28	1.5:1 (14.0)
SP3-1.3	1.35 - 1.535	Plane	19.5	15.4	30	30	1.5:1 (14.0)
SP4-1.3	1.35 - 1.535	Plane	22.0	11.5	30	34	1.5:1 (14.0)
SP6-1.3	1.35 - 1.535	Plane	25.4	7.8	30	38	1.5:1 (14.0)
SP8-1.3	1.35 - 1.535	Plane	29.2	5.7	30	40	1.5:1 (14.0)
1.9 - 2.3 GHz Range							
SP2-2.1	1.9 - 2.3	Plane	20.5	13.7	28	25	1.5:1 (14.0)
SP3-2.1	1.9 - 2.3	Plane	23.0	11.0	30	29	1.5:1 (14.0)
SP4-2.1	1.9 - 2.3	Plane	25.5	8.3	30	33	1.5:1 (14.0)
SP6-2.1	1.9 - 2.3	Plane	28.0	5.6	30	37	1.5:1 (14.0)
SP8-2.1	1.9 - 2.3	Plane	31.5	4.3	30	39	1.5:1 (14.0)
2.4 - 2.7 GHz Range							
SP1-2.4	2.40 - 2.50**	Plane	14.0	28.0	17	25	1.5:1 (14.0)
SP2-2.4	2.40 - 2.70**	Plane	21.3	14.0	28	28	1.5:1 (14.0)
SP3-2.4	2.40 - 2.70**	Plane	24.3	9.5	30	30	1.5:1 (14.0)
SP4-2.4	2.40 - 2.70**	Plane	27.2	7.3	30	34	1.5:1 (14.0)
SP6-2.4	2.40 - 2.70**	Plane	30.3	4.8	30	38	1.5:1 (14.0)
SP8-2.4	2.40 - 2.70**	Plane	33.2	3.6	30	42	1.5:1 (14.0)
3.3 - 3.6 GHz Range *							
SP2-3.5	3.3 - 3.6*	Plane	24.2	10.0	28	32	1.5:1 (14.0)
SP3-3.5	3.3 - 3.6*	Plane	27.7	8.0	30	34	1.5:1 (14.0)
SP4-3.5	3.3 - 3.6*	Plane	30.2	5.0	30	38	1.5:1 (14.0)
SP6-3.5	3.3 - 3.6*	Plane	33.8	3.3	30	40	1.5:1 (14.0)
SP8-3.5	3.3 - 3.6*	Plane	36.3	2.5	30	43	1.5:1 (14.0)
4.4 - 5.0 GHz Range							
SP1-4.7	4.4 - 5.0	Plane	21.2	13.1	20	28	1.5:1 (14.0)
SP2-4.7	4.4 - 5.0	Plane	26.6	7.1	28	34	1.5:1 (14.0)
SP3-4.7	4.4 - 5.0	Plane	30.0	4.7	30	37	1.5:1 (14.0)
SP4-4.7	4.4 - 5.0	Plane	32.6	3.6	30	40	1.5:1 (14.0)
SP6-4.7	4.4 - 5.0	Plane	35.6	2.6	30	43	1.5:1 (14.0)
SP8-4.7	4.4 - 5.0	Plane	39.0	1.8	30	46	1.5:1 (14.0)
5.25 - 5.85 GHz Range							
SP1-5.2	5.25 - 5.85	Plane	22.5	11.1	17	30	1.5:1 (14.0)
SP2-5.2	5.25 - 5.85	Plane	29.0	6.1	28	38	1.5:1 (14.0)
SP3-5.2	5.25 - 5.85	Plane	32.5	4.0	30	40	1.5:1 (14.0)
SP4-5.2	5.25 - 5.85	Plane	34.9	3.0	30	44	1.5:1 (14.0)
SP6-5.2	5.25 - 5.85	Plane	37.9	2.0	30	46	1.5:1 (14.0)
SP8-5.2	5.25 - 5.85	Plane	40.9	1.5	30	52	1.5:1 (14.0)

* Note that 3.3 - 3.6 GHz parabolics can be ordered tuned to 3.5 - 3.8 GHz

** Note that 2.4-2.7 parabolics can be ordered tuned to 2.3 - 2.5 GHz

SP1 Antennas include radome

STANDARD PARABOLIC ANTENNAS: DIAMETERS, WEIGHTS AND ELECTRICAL SPECIFICATIONS

STANDARD PARABOLIC ANTENNAS, SP SERIES - PLANE POLARIZED

ANTENNA DIAMETERS AND WEIGHTS:

1 ft	(0.3m)	- 15 lbs. (6.8 kg)
2 ft	(0.6m)	- 22 lbs. (9.9 kg)
3 ft	(0.9m)	- 35 lbs. (15.8 kg)
4 ft	(1.2m)	- 60 lbs. (27.0 kg)
6 ft	(1.8m)	- 90 lbs. (40.5 kg)
8 ft	(2.4m)	- 250 lbs. (112.5 kg)

ELECTRICAL SPECIFICATIONS (typical performance)

DUAL BAND RANGE - 2.4 - 2.5 & 5.725 - 5.85 GHz RANGES

Model	Frequency,	Polarization	Gain	Beamwidth	X-Pol.	F/B Ratio	VSWR, Max
SP1-2/5	2.40 - 2.50	Plane	14.0	28.0	17	25	1.5:1 (14.0)
	5.725 - 5.85		23.3	11.8	17	30	1.5:1 (14.0)
SP2-2/5	2.40 - 2.50	Plane	21.1	14.0	28	28	1.5:1 (14.0)
	5.725 - 5.85		28.3	6.0	28	38	1.5:1 (14.0)
SP3-2/5	2.40 - 2.50	Plane	24.1	9.5	30	30	1.5:1 (14.0)
	5.725 - 5.85		31.4	4.0	30	40	1.5:1 (14.0)
SP4-2/5	2.40 - 2.50	Plane	27.0	7.3	30	34	1.5:1 (14.0)
	5.725 - 5.85		34.6	2.9	30	44	1.5:1 (14.0)
SP6-2/5	2.40 - 2.50	Plane	30.1	4.8	30	38	1.5:1 (14.0)
	5.725 - 5.85		37.7	2.0	30	46	1.5:1 (14.0)

HIGH PERFORMANCE PARABOLIC ANTENNAS, HP SERIES - PLANE POLARIZED

Model	Frequency,	Polarization	Gain	Beamwidth	X-Pol.	F/B Ratio	VSWR, Max
HP2-5.2	5.25 - 5.85	Plane	28.6	6.1	28	44	1.4:1 (15.5)
HP3-5.2	5.25 - 5.85	Plane	31.2	4.2	30	46	1.4:1 (15.5)
HP4-5.2	5.25 - 5.85	Plane	34.7	3.0	30	49	1.4:1 (15.5)
HP6-5.2	5.25 - 5.85	Plane	37.2	2.0	30	52	1.4:1 (15.5)
HP8-5.2	5.25 - 5.85	Plane	40.7	1.5	30	55	1.4:1 (15.5)

All specifications subject to change without notice

STANDARD PARABOLIC ANTENNAS AND RADOMES: DIAMETERS, WEIGHTS AND ELECTRICAL SPECIFICATIONS

STANDARD PARABOLIC ANTENNAS, SP SERIES - DUAL POLARIZED

ELECTRICAL SPECIFICATIONS (typical performance)

Model Number	Frequency, GHz	Polarization	Gain dBi (nominal)	Beamwidth -3dB	X-Pol. Rejection, dB	F/B Ratio dB	VSWR, Max (R.L., dB)
2.4 - 2.7 GHz Range							
SPD2-2.4	2.40 - 2.70	Dual	21.1	14.0	28	28	1.5:1 (14.0)
SPD3-2.4	2.40 - 2.70	Dual	24.1	9.5	30	30	1.5:1 (14.0)
SPD4-2.4	2.40 - 2.70	Dual	27.0	7.3	30	34	1.5:1 (14.0)
SPD6-2.4	2.40 - 2.70	Dual	30.1	4.8	30	38	1.5:1 (14.0)
SPD8-2.4	2.40 - 2.70	Dual	32.5	3.6	30	39	1.5:1 (14.0)
3.3 - 3.6 GHz Range *							
SPD2-3.5NS	3.3 - 3.6*	Dual	24.2	10.0	28	32	1.5:1 (14.0)
SPD3-3.5NS	3.3 - 3.6*	Dual	27.7	8.0	30	34	1.5:1 (14.0)
SPD4-3.5NS	3.3 - 3.6*	Dual	30.2	5.0	30	38	1.5:1 (14.0)
SPD6-3.5NS	3.3 - 3.6*	Dual	33.8	3.3	30	40	1.5:1 (14.0)
SPD8-3.5NS	3.3 - 3.6*	Dual	36.3	2.5	30	43	1.5:1 (14.0)
4.4 - 5.0 GHz Range							
SPD2-4.7	4.4 - 5.0	Dual	26.6	7.1	28	34	1.5:1 (14.0)
HPD2-4.7	4.4 - 5.0	Dual	26.4	7.1	28	48	1.5:1 (14.0)
SPD3-4.7	4.4 - 5.0	Dual	30.0	4.7	30	37	1.5:1 (14.0)
HPD3-4.7	4.4 - 5.0	Dual	29.8	4.7	30	52	1.5:1 (14.0)
SPD4-4.7	4.4 - 5.0	Dual	32.6	3.6	30	40	1.5:1 (14.0)
HPD4-4.7	4.4 - 5.0	Dual	32.4	3.6	30	54	1.5:1 (14.0)
SPD6-4.7	4.4 - 5.0	Dual	35.6	2.6	30	43	1.5:1 (14.0)
HPD6-4.7	4.4 - 5.0	Dual	35.4	2.6	30	57	1.5:1 (14.0)
SPD8-4.7	4.4 - 5.0	Dual	39.0	1.6	30	46	1.5:1 (14.0)
HPD8-4.7	4.4 - 5.0	Dual	38.8	1.6	30	61	1.5:1 (14.0)
5.25 - 5.85 GHz Range							
SPD2-5.2	5.25 - 5.85	Dual	29.0	6.2	30	38	1.5:1 (14.0)
HPD2-5.2	5.25 - 5.85	Dual	28.8	6.1	28	44	1.5:1 (14.0)
SPD3-5.2	5.25 - 5.85	Dual	32.5	4.2	30	40	1.5:1 (14.0)
HPD3-5.2	5.25 - 5.85	Plane	32.3	4.2	30	46	1.4:1 (15.5)
SPD4-5.2	5.25 - 5.85	Dual	34.9	3.1	30	44	1.5:1 (14.0)
HPD4-5.2	5.25 - 5.85	Dual	34.7	3.0	30	49	1.5:1 (14.0)
SPD6-5.2	5.25 - 5.85	Dual	37.9	2.1	30	46	1.5:1 (14.0)
HPD6-5.2	5.25 - 5.85	Plane	37.7	2.0	30	52	1.4:1 (15.5)
SPD8-5.2	5.25 - 5.85	Dual	40.9	1.6	30	52	1.5:1 (14.0)
HPD8-5.2	5.25 - 5.85	Plane	40.7	1.5	30	55	1.4:1 (15.5)

* Note that 3.3 - 3.6 GHz parabolics can be ordered tuned to 3.5 - 3.8 GHz

All specifications subject to change without notice.

RADOMES, RD SERIES, RADOMES ARE FACTORY ATTACHED FOR 2, 3, 4 & 8 FT MODELS AT NO CHARGE. RADOME DIAMETERS AND WEIGHTS:

2 ft	(0.6m) - 4 lbs. (1.8 kg)
3 ft	(0.9m) - 8 lbs. (3.6 kg)
4 ft	(1.2m) - 20 lbs. (9.0 kg)
6 ft	(1.8m) - 30 lbs. (13.5 kg)
8 ft	(2.4m) - 70 lbs. (31.5 kg)

ELECTRICAL SPECIFICATIONS (typical performance)

Model Number	Diameter ft. (m)	Attenuation					Add to antenna VSWR, Max				
		2 GHz	5 GHz	7GHz	10 GHz	13 GHz	2 GHz	5 GHz	7 GHz	10 GHz	13 GHz
RD2	2 (0.6)	0.2	0.4	0.5	0.6	0.7	0.02	0.02	0.02	0.03	0.04
RD3	3 (0.9)	0.2	0.4	0.5	0.6	0.7	0.02	0.02	0.02	0.03	0.04
RD4	4 (1.2)	0.2	0.4	0.5	0.6	0.7	0.02	0.02	0.02	0.03	0.04
RD6	6 (1.8)	0.2	0.4	0.5	0.6	0.7	0.02	0.02	0.02	0.03	0.04
RD8	8 (2.4)	0.2	0.4	0.5	0.6	0.7	0.02	0.02	0.02	0.03	0.04

XCELARATOR®

Radio Waves Xcelerator® Flat Panels for the Unlicensed 4 GHz and 5 GHz Bands



Radio Waves Xcelerator® series of flat panels for the 4 and 5 GHz unlicensed bands offer significant performance benefits over competing brand's panel antennas at a competitive price! These antennas are ideal for point to point or any low profile antenna Wi-Fi 802.11 applications. Choose from the three Xcelerator models to best suite your application.

Features of the Xcelerator® include:

- Enhanced system performance in an aesthetically pleasing package.
- Superior VSWR of 1.4:1 across the band.
- Excellent front-to-back ratio of 40 db.
- Superior side lobe performance compared to competing brands.
- Superior design and construction for years of reliable service.
- Less than 1/2" thick.
- Industry leading 5 year warranty - like all Radio Waves high quality antennas.

***The Radio Waves Xcelerator® Flat Panels for Unlicensed 5 GHz... Panels for 4.4 - 5.0 GHz...
...Why Choose Any Other Flat Panel?***



978-459-8800 • 978-459-3310 Fax

Radio Waves, Inc.
<http://www.radiowavesinc.com> 27

GRID AND FLAT PANEL LOW PROFILE ANTENNAS: DIAMETERS, WEIGHTS AND ELECTRICAL SPECIFICATIONS

GRID PARABOLIC ANTENNAS, G-SERIES

ANTENNA DIAMETERS AND WEIGHTS:

3 ft	(0.9m) - 25 lbs. (11.3 kg)
4 ft	(1.2m) - 35 lbs. (15.8 kg)
6 ft	(1.8m) - 80 lbs. (36.0 kg)

ELECTRICAL SPECIFICATIONS (typical performance)

1.35-1.535 GHz, 1.7 - 2.1 GHz, 1.9 - 2.3 GHz, 2.4-2.7 AND 4.4 - 5.0 GHz RANGES

Model Number	Frequency, GHz	Gain, dBi Mid	Beamwidth -3dB	X-Pol. Rejection, dB	F/B Ratio dB	VSWR, Max (R.L., dB)
G3-1.3NF	1.35 - 1.535	20.1	15.5	27	23	1.5:1 (14.0)
G4-1.3NF	1.35 - 1.535	22.1	11.6	27	25	1.5:1 (14.0)
G6-1.3NF	1.35 - 1.535	25.6	8.2	30	30	1.5:1 (14.0)
G4-1.9NF	1.70 - 2.10	25.2	8.8	30	26	1.4:1 (15.5)
G4-2.1NF	1.93 - 2.30	26.0	8.9	30	25	1.5:1 (14.0)
G6-2.1NF	1.93 - 2.30	29.1	5.8	30	28	1.5:1 (14.0)
G3-2.4NF	2.4 - 2.7	24.5	9.2	25	28	1.5:1 (14.0)
G4-2.4NF	2.4 - 2.7	27.0	7.1	25	30	1.5:1 (14.0)
G6-2.4NF	2.4 - 2.7	30.3	4.6	25	32	1.5:1 (14.0)
G2-4.7NF	4.4-5.0	26.4	7.1	28	28	1.5:1 (14.0)
G3-4.7NF	4.4-5.0	29.8	4.7	30	32	1.5:1 (14.0)
G2-4.7D*	4.4 - 5.0	26.4	7.1	28	28	1.5:1 (14.0)
G3-4.7D*	4.4 - 5.0	29.8	4.7	30	32	1.5:1 (14.0)
G3-5.2NF	5.25 - 5.85	31.1	4.2	30	30	1.5:1 (14.0)

All specifications subject to change without notice

XCELARATOR[®] FLAT PANEL ANTENNAS, FP-SERIES

ANTENNA DIAMETERS AND WEIGHTS:

FP.5	0.5 ft (0.15m) - 3 lbs. (1.4 kg)
FP1	1.0 ft (0.3m) - 5 lbs. (2.3 kg)

ELECTRICAL SPECIFICATIONS (typical performance)

4.4-5.0 GHz RANGE XCELARATOR[®] SERIES

Model Number	Frequency, GHz	Polarization	Gain dBi (nominal)	Beamwidth ° -3dB	X-Pol. Rejection, dB	F/B Ratio dB	VSWR, Max (R.L., dB)
FP.5-4.7-18	4.4 - 5.0	Single	17.0	24	25	30	1.5:1 (14.0)
FP1-4.7-24	4.4 - 5.0	Single	22.5	12	30	35	1.5:1 (14.0)
FP2-4.7-28	4.4 - 5.0	Single	26.5	6	30	35	1.5:1 (14.0)
FPD-4.7-18	4.4 - 5.0	Dual	17.0	24	20	30	1.5:1 (14.0)

5.25-5.85 GHz RANGE XCELARATOR[®] SERIES

Model Number	Frequency, GHz	Polarization	Gain dBi (nominal)	Beamwidth ° -3dB	X-Pol. Rejection, dB	F/B Ratio dB	VSWR, Max (R.L., dB)
FP.5-5-18	5.15 - 5.85	Single	18.0	20	25	35	1.4:1 (15.5)
FP1-5-24	5.15 - 5.85	Single	24.0	10	30	40	1.4:1 (15.5)
FP2-5-28	5.15 - 5.85	Single	28.2	4.5	30	45	1.4:1 (15.5)
FPD.5-5-18	5.25 - 5.85	Dual	18.0	20	20	35	1.5:1 (14.0)

All specifications subject to change without notice.

RADIO WAVES POINT-TO-POINT PARABOLIC ANTENNAS

Radio Waves ProLine parabolic microwave antennas are available in sizes of 1 to 8 feet (0.3 to 2.4 meter) in diameter and frequency ranges from 1.3 to 86 GHz. (Note that not all sizes are available at each frequency band.) Parabolic Antenna construction typically consists of a single piece of spun aluminum employing a dipole, waveguide or proprietary center-fed design. The antenna's mount is fabricated of cast aluminum, incorporating fine azimuth and elevation adjustments for ease of alignment. High Performance antenna designs typically utilize an aluminum shroud and absorber material to suppress side lobes and improve front-to-back performance. Careful selection of mechanical components is required to assure long life and corrosion-free performance. antenna is most applicable.



Standard Performance (SP and SPD Series)

Un-shrouded (standard) parabolic antennas are spun aluminum reflectors that feature cast aluminum mounts and are available with either plane (SP) or dual polarized (SPD) feed assemblies. Standard models utilize optional ABS conical radomes for reduced windloading and feed assembly protection. Radio Waves' standard one-foot antenna models are supplied with an integrated radome. On larger Radio Waves antenna models, ABS conical radomes are an option. Standard Performance non-shrouded designs provide an economical point-to-point solution for applications that allow relaxed side lobe and front-to-back electrical operating characteristics.



High Performance (HP and HPD Series)

Shrouded (high performance) parabolic antennas are spun aluminum reflectors that feature cast aluminum or galvanized mounts. These are available in either plane (HP) or dual polarized (HPD) feed assemblies. High Performance shrouded antenna designs are for microwave applications that require more stringent radiation side lobe and front-to-back suppression characteristics and where frequency congestion and coordination are demanded. The



Discriminator™ (HPCPE) is a unique ultra high performance one foot (1 ft., 0.3m) parabolic design which utilizes a specially-shaped reflector. The Discriminator™ provides for superior side lobe performance in a lightweight and cost effective package.

High Performance Discriminator™ Low Side Lobe Design 23, 26, 28, 31, 38, 60 & 80 GHz Bands

Key Features

- Antenna Diameter: 12" square
- 23 GHz Version FCC Category A
- Windloads:
 - Survival- 125 mph (210 km/h)
- Low side lobe design, typically -23 dB
- Lightweight and rugged design, easily installed
- Radio Mounting kits available to integrate with major OEM ratios
- Standard antenna mount provides fine adjustment for both azimuth and elevation
- Accomodates a 2.25 in. to 4.5 in. diameter pipe.
- Five Year Warranty



Antenna Specifications, Electrical (typical)

Model #	HPCPE-23	HPCPE-26	HPCPE-28	HPCPE-31	HPCPE-38	HPCPE-60	HPCPE-80
Frequency, GHz	21.2-23.6	24.25-26.5	27.3-29.5	29.5-31.3	37.0-40.0	57.0-64.0	71.0 - 86.0
Gain,							
Low	34.0 dBi	35.3 dBi	35.8 dBi	36.3 dBi	38.5 dBi	41.0 dBi	43.0 dBi
Mid	34.4 dBi	35.7 dBi	36.1 dBi	36.6 dBi	38.7 dBi	42.0 dBi	43.8dBi
High	34.8 dBi	35.9 dBi	36.3 dBi	36.8 dBi	38.9 dBi	43.0 dBi	44.6 dBi
Beamwidth, -3dB	2.9 deg.	2.6 deg.	2.2 deg.	2.1 deg.	1.7 deg.	1.2 deg.	0.9 deg.
X-Pol disc.	-30 dB	-30 dB	-30 dB	-30 dB	-30 dB	-30 dB	-30 dB
Front-to-back ratio	-60 dB	-62 dB	-64 dB	-64 dB	-64 dB	-64 dB	-64 dB
1st side lobe	-23 dB	-23 dB	-23 dB	-23 dB	-23 dB	-23 dB	-23 dB
VSRWR, max	1.37:1	1.5:1	1.5:1	1.5:1	1.5:1	1.5:1	1.5:1
R.L., dB	16.1	14.0	14.0	14.0	14.0	14.0	14.0
Flange Type/Interface:	WR-42	WR-42	WR-28	WR-28	WR-28	WR-15	WR-12
	FCC A						
Regulation	ETS301215-2 TS2 & TS3	ETS301215-2 TS2 & TS3	ETS301215-2 TS2 & TS3	ETS301215-2 TS2 & TS3	ETS301215-2 TS2 & TS3	ETS301215-2 TS2 & TS3	ETS301215-2 TS2 & TS3
	ETS300833 Range 4 CL2	ETS300833 Range 4 CL2	ETS300833 Range 4 CL2	ETS300833 Range 5 CL2	ETS300833 Range 5 CL2	ETS300833 Range 5 CL2	ETS300833 Range 5 CL2

Note: Specification subject to change without notice.

ELECTRICAL SPECIFICATIONS- PARABOLIC ANTENNAS

5.725-6.425 GHz (CPR137G)

Model Number	Frequency, GHz	Diameter ft. (m)	3dB BW degs	Gain, dBi			XPD dB	F/B Ratio dB	VSWR, Max (R.L., dB)
				Low	Mid	High			
Standard Parabolic - Plane Polarized									
SP4-57	5.725-6.425	4 (1.2)	3.0	35.3	35.8	36.3	28	42	1.4:1 (15.5)
SP6-57	5.725-6.425	6 (1.8)	2.0	38.8	39.3	39.8	30	46	1.4:1 (15.5)

5.925-6.425 GHz (CPR137G)

Model Number	Frequency, GHz	Diameter ft. (m)	3dB BW degs	Gain, dBi			XPD dB	F/B Ratio dB	VSWR, Max (R.L., dB)
				Low	Mid	High			
High Performance - Plane Polarized									
HP4-59	5.925-6.425	4 (1.2)	2.7	35.5	36.0	36.5	28	60	1.37:1 (16.1)
HP6-59	5.925-6.425	6 (1.8)	1.9	38.5	39.0	39.3	30	62	1.37:1 (16.1)
HP8-59	5.925-6.425	8 (2.4)	1.5	41.3	41.7	42.1	30	66	1.37:1 (16.1)
High Performance - Dual Polarized									
HPD4-59	5.925-6.425	4 (1.2)	2.7	35.2	35.7	36.2	28	60	1.37:1 (16.1)
HPD6-59	5.925-6.425	6 (1.8)	1.9	38.2	38.7	39.0	30	62	1.37:1 (16.1)
HPD8-59	5.925-6.425	8 (2.4)	1.5	41.0	41.4	41.8	30	66	1.37:1 (16.1)
Standard Deep Reflector - Plane Polarized									
DP6-59*	5.925-6.425	6 (1.8)	2.0	38.0	38.3	38.5	30	55	1.22:1 (20.0)
Standard Deep Reflector - Dual Polarized									
DPD6-59*	5.925-6.425	6 (1.8)	2.0	37.8	38.1	38.3	30	55	1.22:1 (20.0)
Standard Parabolic - Plane Polarized									
SP4-59	5.925-6.425	4 (1.2)	2.7	35.7	36.2	36.7	28	42	1.37:1 (16.1)
SP6-59	5.925-6.425	6 (1.8)	1.9	38.7	39.2	39.5	30	46	1.37:1 (16.1)
SP8-59**	5.925-6.425	8 (2.4)	1.5	41.5	41.9	42.3	30	48	1.37:1 (16.1)
Standard Parabolic - Dual Polarized									
SPD4-59	5.925-6.425	4 (1.2)	2.7	35.4	35.9	36.4	28	42	1.37:1 (16.1)
SPD6-59	5.925-6.425	6 (1.8)	1.9	38.4	38.9	39.1	30	46	1.37:1 (16.1)
SPD8-59**	5.925-6.425	8 (2.4)	1.5	41.2	41.6	42.0	30	48	1.37:1 (16.1)

6.425-7.125 GHz (CPR137G)

Model Number	Frequency, GHz	Diameter ft. (m)	3dB BW degs	Gain, dBi			XPD dB	F/B Ratio dB	VSWR, Max (R.L., dB)
				Low	Mid	High			
High Performance - Plane Polarized									
HP2-64	6.425-7.125	2 (1.6)	5.2	29.5	29.9	30.3	28	54	1.37:1 (16.1)
HP3-64	6.425-7.125	4 (1.2)	3.5	33.0	33.4	33.8	28	57	1.37:1 (16.1)
HP4-64	6.425-7.125	4 (1.2)	2.6	35.5	35.9	36.3	28	60	1.37:1 (16.1)
HP6-64	6.425-7.125	6 (1.8)	1.8	38.9	39.1	39.4	30	64	1.37:1 (16.1)
HP8-64	6.425-7.125	8 (2.4)	1.4	41.9	42.3	42.8	30	66	1.37:1 (16.1)
High Performance - Dual Polarized									
HPD2-64	6.425-7.125	2 (0.6)	5.2	29.3	29.7	30.1	28	54	1.37:1 (16.1)
HPD3-64	6.425-7.125	3 (0.9)	3.5	32.8	33.2	33.6	30	57	1.37:1 (16.1)
HPD4-64	6.425-7.125	4 (1.2)	2.6	35.3	35.7	36.1	30	60	1.37:1 (16.1)
HPD6-64	6.425-7.125	6 (1.8)	1.8	38.7	38.9	39.2	30	64	1.37:1 (16.1)
HPD8-64	6.425-7.125	8 (2.4)	1.4	41.6	42.1	42.5	30	66	1.37:1 (16.1)
Standard Deep Reflector - Plane Polarized									
DP6-64*	6.425-7.125	6 (1.8)	1.9	38.7	38.8	39.0	30	59	1.22:1 (20.1)
Standard Deep Reflector - Dual Polarized									
DPD6-64*	6.425-7.125	6 (1.8)	1.9	38.5	38.6	38.8	30	59	1.22:1 (20.1)
Standard Parabolic - Plane Polarized									
SP2-64	6.425-7.125	2 (0.6)	5.2	29.7	30.1	30.5	28	37	1.37:1 (16.1)
SP3-64	6.425-7.125	3 (0.9)	3.5	33.2	33.6	34.0	28	40	1.37:1 (16.1)
SP4-64	6.425-7.125	4 (1.2)	2.6	35.9	36.4	36.9	28	43	1.37:1 (16.1)
SP6-64	6.425-7.125	6 (1.8)	1.8	39.0	39.2	39.5	30	47	1.37:1 (16.1)
SP8-64	6.425-7.125	8 (2.4)	1.4	41.9	42.5	42.9	30	49	1.37:1 (16.1)
Standard Parabolic - Dual Polarized									
SPD2-64	6.425-7.125	2 (0.6)	5.2	29.7	30.1	30.5	28	37	1.37:1 (16.1)
SPD3-64	6.425-7.125	3 (0.9)	3.5	33.2	33.6	34.0	28	40	1.37:1 (16.1)
SPD4-64	6.425-7.125	4 (1.2)	2.6	35.7	36.2	36.7	28	43	1.37:1 (16.1)
SPD6-64	6.425-7.125	6 (1.8)	1.8	39.0	39.2	39.5	30	47	1.37:1 (16.1)
SPD8-64	6.425-7.125	8 (2.4)	1.4	41.7	42.3	42.7	30	49	1.37:1 (16.1)

* Must use with RD6 radome and SST-4/6 side strut.

**Operate at 5.75 - 5.85 GHz with 1 dB less gain and 15 dB return

Radio Waves, Inc.

978-459-8800 • 978-459-3310 Fax

ELECTRICAL SPECIFICATIONS- PARABOLIC ANTENNAS

7.125-7.750 GHz (CPR112G)

Model Number	Frequency, GHz	Diameter ft. (m)	3dB BW degs	Gain, dBi			XPD dB	F/B Ratio dB	VSWR, Max (R.L., dB)
				Low	Mid	High			
High Performance - Plane Polarized									
HP2-7	7.125-7.750	2 (0.6)	4.6	30.3	30.7	31.1	30	60	1.37:1 (16.1)
HP3-7	7.125-7.750	3 (0.9)	3.0	33.7	33.9	34.4	30	61	1.37:1 (16.1)
HP4-7	7.125-7.750	4 (1.2)	2.3	36.3	36.7	37.1	30	64	1.37:1 (16.1)
HP6-7	7.125-7.750	6 (1.8)	1.5	39.5	39.9	40.3	30	67	1.37:1 (16.1)
HP8-7	7.125-7.750	8 (2.4)	1.1	42.4	42.8	43.1	30	68	1.37:1 (16.1)
High Performance - Dual Polarized									
HPD2-7	7.125-7.750	2 (0.6)	4.6	30.1	30.5	30.9	30	60	1.37:1 (16.1)
HPD3-7	7.125-7.750	3 (0.9)	3.0	33.5	33.7	34.2	30	61	1.37:1 (16.1)
HPD4-7	7.125-7.750	4 (1.2)	2.3	36.1	36.5	36.9	30	64	1.37:1 (16.1)
HPD6-7	7.125-7.750	6 (1.8)	1.5	39.3	39.7	40.1	30	67	1.37:1 (16.1)
HPD8-7	7.125-7.750	8 (2.4)	1.1	42.2	42.6	42.9	30	68	1.37:1 (16.1)
Standard Parabolic - Plane Polarized									
SP2-7	7.125-7.750	2 (0.6)	4.6	30.5	30.9	31.3	30	40	1.37:1 (16.1)
SP3-7	7.125-7.750	3 (0.9)	3.0	33.9	34.1	34.6	30	43	1.37:1 (16.1)
SP4-7	7.125-7.750	4 (1.2)	2.3	36.5	36.9	37.3	30	46	1.37:1 (16.1)
SP6-7	7.125-7.750	6 (1.8)	1.5	39.9	40.3	40.7	30	48	1.37:1 (16.1)
SP8-7	7.125-7.750	8 (2.4)	1.1	42.4	43.0	43.2	30	50	1.37:1 (16.1)
Standard Parabolic - Dual Polarized									
SPD2-7	7.125-7.750	2 (0.6)	4.6	30.3	30.7	31.1	30	40	1.37:1 (16.1)
SPD3-7	7.125-7.750	3 (0.9)	3.0	33.7	33.9	34.4	30	43	1.37:1 (16.1)
SPD4-7	7.125-7.750	4 (1.2)	2.3	36.3	36.7	37.1	30	46	1.37:1 (16.1)
SPD6-7	7.125-7.750	6 (1.8)	1.5	39.7	40.1	40.5	30	48	1.37:1 (16.1)
SPD8-7	7.125-7.750	8 (2.4)	1.1	42.2	42.8	43.0	30	50	1.37:1 (16.1)

7.125-8.5 GHz (CPR112G)

Model Number	Frequency, GHz	Diameter ft. (m)	3dB BW degs	Gain, dBi			XPD dB	F/B Ratio dB	VSWR, Max (R.L., dB)
				Low	Mid	High			
High Performance - Plane Polarized									
HP2-77	7.125-8.5	2 (0.6)	4.2	30.0	30.8	31.6	30	54	1.37:1 (16.1)
HP3-77	7.125-8.5	3 (0.9)	3.3	33.7	34.4	35.1	30	60	1.37:1 (16.1)
HP4-77	7.125-8.5	4 (1.2)	2.4	36.4	36.8	37.2	30	64	1.37:1 (16.1)
HP6-77	7.125-8.5	6 (1.8)	1.5	39.5	40.3	40.7	30	67	1.37:1 (16.1)
HP8-77	7.125-8.5	8 (2.4)	1.1	42.7	43.2	43.6	30	68	1.37:1 (16.1)
High Performance - Dual Polarized									
HPD2-77	7.125-8.5	2 (0.6)	4.2	29.8	30.6	31.4	30	54	1.37:1 (16.1)
HPD3-77	7.125-8.5	3 (0.9)	3.3	33.5	34.2	34.9	30	60	1.37:1 (16.1)
HPD4-77	7.125-8.5	4 (1.2)	2.4	36.2	36.6	37.0	30	64	1.37:1 (16.1)
HPD6-77	7.125-8.5	6 (1.8)	1.5	39.3	40.1	40.5	30	67	1.37:1 (16.1)
HPD8-77	7.125-8.5	8 (2.4)	1.1	42.5	43.0	43.4	30	68	1.37:1 (16.1)
Standard Parabolic - Plane Polarized									
SP2-77	7.125-8.5	2 (0.6)	4.2	30.1	30.9	31.7	30	40	1.37:1 (16.1)
SP3-77	7.125-8.5	3 (0.9)	3.3	33.9	34.5	35.2	30	44	1.37:1 (16.1)
SP4-77	7.125-8.5	4 (1.2)	2.4	36.6	37.0	37.4	30	45	1.37:1 (16.1)
SP6-77	7.125-8.5	6 (1.8)	1.5	39.7	40.5	40.9	30	49	1.37:1 (16.1)
SP8-77	7.125-8.5	8 (2.4)	1.1	42.9	43.4	43.8	30	50	1.37:1 (16.1)
Standard Parabolic - Dual Polarized									
SPD2-77	7.125-8.5	2 (0.6)	4.2	30.1	30.7	31.5	30	40	1.37:1 (16.1)
SPD3-77	7.125-8.5	3 (0.9)	3.3	33.7	34.3	35.0	30	44	1.37:1 (16.1)
SPD4-77	7.125-8.5	4 (1.2)	2.4	36.4	37.0	37.2	30	45	1.37:1 (16.1)
SPD6-77	7.125-8.5	6 (1.8)	1.5	39.5	40.3	40.7	30	49	1.37:1 (16.1)
SPD8-77	7.125-8.5	8 (2.4)	1.1	42.0	43.2	43.6	30	50	1.37:1 (16.1)

All specifications subject to change without notice.

ELECTRICAL SPECIFICATIONS- PARABOLIC ANTENNAS

7.750-8.500 GHz (CPR112G)

Model Number	Frequency, GHz	Diameter ft. (m)	3dB BW degs	Gain, dBi			XPD dB	F/B Ratio dB	VSWR, Max (R.L., dB)
				Low	Mid	High			
High Performance - Plane Polarized									
HP2-8	7.750-8.500	2 (0.6)	4.5	30.4	31.0	31.6	30	54	1.37:1 (16.1)
HP3-8	7.750-8.500	3 (0.9)	3.0	33.9	34.5	35.1	30	56	1.37:1 (16.1)
HP4-8	7.750-8.500	4 (1.2)	2.3	36.4	37.0	37.6	30	62	1.37:1 (16.1)
HP6-8	7.750-8.500	6 (1.8)	1.5	40.1	40.4	40.8	30	66	1.37:1 (16.1)
HP8-8	7.750-8.500	8 (2.4)	1.1	42.7	43.1	43.5	30	68	1.37:1 (16.1)
High Performance - Dual Polarized									
HPD2-8	7.750-8.500	2 (0.6)	4.5	30.2	30.8	31.4	30	54	1.37:1 (16.1)
HPD3-8	7.750-8.500	3 (0.9)	3.0	33.7	34.3	34.9	30	56	1.37:1 (16.1)
HPD4-8	7.750-8.500	4 (1.2)	2.3	36.2	36.8	37.4	30	62	1.37:1 (16.1)
HPD6-8	7.750-8.500	6 (1.8)	1.5	39.9	40.2	40.6	30	66	1.37:1 (16.1)
HPD8-8	7.750-8.500	8 (2.4)	1.1	42.5	42.9	43.3	30	68	1.37:1 (16.1)
Standard Parabolic - Plane Polarized									
SP2-8	7.750-8.500	2 (0.6)	4.5	30.6	31.1	31.7	30	40	1.37:1 (16.1)
SP3-8	7.750-8.500	3 (0.9)	3.0	34.0	34.6	35.3	30	42	1.37:1 (16.1)
SP4-8	7.750-8.500	4 (1.2)	2.3	36.5	37.1	37.7	30	45	1.37:1 (16.1)
SP6-8	7.750-8.500	6 (1.8)	1.5	40.3	40.6	40.9	30	48	1.37:1 (16.1)
SP8-8	7.750-8.500	8 (2.4)	1.1	42.9	43.3	43.7	30	50	1.37:1 (16.1)
Standard Parabolic - Dual Polarized									
SPD2-8	7.750-8.500	2 (0.6)	4.5	30.4	31.0	31.6	30	40	1.37:1 (16.1)
SPD3-8	7.750-8.500	3 (0.9)	3.0	33.8	34.4	35.1	30	42	1.37:1 (16.1)
SPD4-8	7.750-8.500	4 (1.2)	2.3	36.3	36.9	37.5	30	45	1.37:1 (16.1)
SPD6-8	7.750-8.500	6 (1.8)	1.5	40.0	40.4	40.7	30	48	1.37:1 (16.1)
SPD8-8	7.750-8.500	8 (2.4)	1.1	42.7	43.1	43.5	30	50	1.37:1 (16.1)

10.5-10.7 GHz (CPR90G)

Model Number	Frequency, GHz	Diameter ft. (m)	3dB BW degs	Gain, dBi			XPD dB	F/B Ratio dB	VSWR, Max (R.L., dB)
				Low	Mid	High			
High Performance - Plane Polarized									
HPCPE-10	10.5-10.7	1 (0.3)	7.2	26.8	26.9	27.0	25	42	1.37:1 (16.1)
HPLP1-10	10.5-10.7	1 (0.3)	7.1	27.0	27.1	27.2	25	43	1.37:1 (16.1)
HP2-10	10.5-10.7	2 (0.6)	3.6	33.8	33.9	34.0	30	54	1.37:1 (16.1)
HP3-10	10.5-10.7	3 (0.9)	2.8	36.6	36.7	36.8	30	56	1.37:1 (16.1)
HP4-10	10.5-10.7	4 (1.2)	1.9	40.0	40.1	40.2	30	60	1.37:1 (16.1)
HP6-10	10.5-10.7	6 (1.8)	1.3	43.4	43.5	43.6	30	67	1.37:1 (16.1)
HP8-10	10.5-10.7	8 (2.4)	1.0	45.7	45.8	45.9	30	70	1.37:1 (16.1)
High Performance - Dual Polarized									
HPD2-10	10.5-10.7	2 (0.6)	3.6	33.6	33.7	33.8	30	54	1.37:1 (16.1)
HPD3-10	10.5-10.7	3 (0.9)	2.8	36.4	36.5	36.6	30	56	1.37:1 (16.1)
HPD4-10	10.5-10.7	4 (1.2)	1.9	39.8	39.9	40.0	30	60	1.37:1 (16.1)
HPD6-10	10.5-10.7	6 (1.8)	1.3	43.2	43.3	43.4	30	67	1.37:1 (16.1)
HPD8-10	10.5-10.7	8 (2.4)	1.0	45.5	45.6	45.7	30	70	1.37:1 (16.1)
Standard Deep Reflector - Plane Polarized									
DP6-10	10.5-10.7	6 (1.8)	1.3	43.0	43.1	43.2	30	60	1.37:1 (16.1)
Standard Deep Reflector - Dual Polarized									
DPD6-10	10.5-10.7	6 (1.8)	1.3	42.8	42.9	43.0	30	60	1.37:1 (16.1)
Standard Parabolic - Plane Polarized									
SP2-10	10.5-10.7	2 (0.6)	3.6	33.9	34.0	34.1	30	40	1.37:1 (16.1)
SP3-10	10.5-10.7	3 (0.9)	2.8	36.8	36.9	37.0	30	44	1.37:1 (16.1)
SP4-10	10.5-10.7	4 (1.2)	1.9	40.2	40.3	40.4	30	46	1.37:1 (16.1)
SP6-10	10.5-10.7	6 (1.8)	1.3	43.6	43.7	43.8	30	50	1.37:1 (16.1)
SP8-10	10.5-10.7	8 (2.4)	1.0	45.8	45.9	46.0	30	52	1.37:1 (16.1)
Standard Parabolic - Dual Polarized									
SPD2-10	10.5-10.7	2 (0.6)	3.6	33.7	33.8	33.9	30	40	1.37:1 (16.1)
SPD3-10	10.5-10.7	3 (0.9)	2.8	36.6	36.7	36.8	30	44	1.37:1 (16.1)
SPD4-10	10.5-10.7	4 (1.2)	1.9	40.0	40.1	40.2	30	46	1.37:1 (16.1)
SPD6-10	10.5-10.7	6 (1.8)	1.3	43.4	43.5	43.6	30	50	1.37:1 (16.1)
SPD8-10	10.5-10.7	8 (2.4)	1.0	45.6	45.7	45.8	30	52	1.37:1 (16.1)

All specifications subject to change without notice.

ELECTRICAL SPECIFICATIONS- PARABOLIC ANTENNAS

10.5-11.7 GHz (CPR90G)

Model Number	Frequency, GHz	Diameter ft. (m)	3dB BW degs	Gain, dBi			XPD dB	F/B Ratio dB	VSWR, Max (R.L., dB)
				Low	Mid	High			
High Performance - Plane Polarized									
HPCPE-1011	10.5-11.7	1 (0.3)	7.0	26.8	27.3	27.8	25	42	1.37:1 (16.1)
HPLP1-1011	10.5-11.7	1 (0.3)	6.9	27.0	27.5	28.0	25	43	1.37:1 (16.1)
HP2-1011	10.5-11.7	2 (0.6)	3.4	33.8	34.3	34.8	30	54	1.37:1 (16.1)
HP3-1011	10.5-11.7	3 (0.9)	2.6	36.6	37.1	37.8	30	56	1.37:1 (16.1)
HP4-1011	10.5-11.7	4 (1.2)	1.7	40.0	40.4	40.8	30	60	1.37:1 (16.1)
HP6-1011	10.5-11.7	6 (1.8)	1.1	43.4	43.8	44.2	30	67	1.37:1 (16.1)
HP8-1011	10.5-11.7	8 (2.4)	0.8	45.7	46.2	46.7	30	70	1.37:1 (16.1)
High Performance - Dual Polarized									
HPD2-1011	10.5-11.7	2 (0.6)	3.4	33.6	34.1	34.6	30	54	1.37:1 (16.1)
HPD3-1011	10.5-11.7	3 (0.9)	2.6	36.4	36.9	37.6	30	56	1.37:1 (16.1)
HPD4-1011	10.5-11.7	4 (1.2)	1.7	39.8	40.2	40.6	30	60	1.37:1 (16.1)
HPD6-1011	10.5-11.7	6 (1.8)	1.1	43.2	43.6	44.0	30	67	1.37:1 (16.1)
HPD8-1011	10.5-11.7	8 (2.4)	0.8	45.5	46.0	46.5	30	70	1.37:1 (16.1)
Standard Deep Reflector - Plane Polarized									
DP6-1011	10.5-11.7	6 (1.8)	1.2	38.0	38.3	38.5	30	55	1.37:1 (16.1)
Standard Deep Reflector - Dual Polarized									
DPD6-1011	10.5-11.7	6 (1.8)	1.8	37.8	38.1	38.3	30	55	1.37:1 (16.1)
Standard Parabolic - Plane Polarized									
SP2-1011	10.5-11.7	2 (0.6)	3.4	33.9	34.4	34.9	30	40	1.37:1 (16.1)
SP3-1011	10.5-11.7	3 (0.9)	2.6	36.7	37.2	37.9	30	44	1.37:1 (16.1)
SP4-1011	10.5-11.7	4 (1.2)	1.7	40.2	40.5	40.9	30	46	1.37:1 (16.1)
SP6-1011	10.5-11.7	6 (1.8)	1.2	43.6	44.0	44.4	30	50	1.37:1 (16.1)
SP8-1011	10.5-11.7	8 (2.4)	0.8	45.8	46.3	46.8	30	52	1.37:1 (16.1)
Standard Parabolic - Dual Polarized									
SPD2-1011	10.5-11.7	2 (0.6)	3.4	33.7	34.2	34.9	30	40	1.37:1 (16.1)
SPD3-1011	10.5-11.7	3 (0.9)	2.6	36.5	37.0	37.7	30	44	1.37:1 (16.1)
SPD4-1011	10.5-11.7	4 (1.2)	1.7	40.0	40.3	40.7	30	46	1.37:1 (16.1)
SPD6-1011	10.5-11.7	6 (1.8)	1.1	43.4	43.8	44.2	30	50	1.37:1 (16.1)
SPD8-1011	10.5-11.7	8 (2.4)	0.8	45.6	46.1	46.6	30	52	1.37:1 (16.1)

10.7-11.7 GHz (CPR90G)

Model Number	Frequency, GHz	Diameter ft. (m)	3dB BW degs	Gain, dBi			XPD dB	F/B Ratio dB	VSWR, Max (R.L., dB)
				Low	Mid	High			
High Performance - Plane Polarized									
HPCPE-11	10.7-11.7	1 (0.3)	7.0	27.2	27.5	27.8	25	42	1.37:1 (16.1)
HPLP1-11	10.7-11.7	1 (0.3)	6.9	27.3	27.7	28.0	25	43	1.37:1 (16.1)
HP2-11	10.7-11.7	2 (0.6)	3.4	34.2	34.5	34.8	30	55	1.37:1 (16.1)
HPLP2-11	10.7-11.7	2 (0.6)	3.4	34.2	34.5	34.8	30	50	1.37:1 (16.1)
HP3-11	10.7-11.7	3 (0.9)	2.2	37.4	37.6	37.8	30	62	1.37:1 (16.1)
HP4-11	10.7-11.7	4 (1.2)	1.7	40.0	40.4	40.8	30	64	1.37:1 (16.1)
HP6-11	10.7-11.7	6 (1.8)	1.1	43.1	43.4	43.8	30	66	1.37:1 (16.1)
HP8-11	10.7-11.7	8 (2.4)	0.8	45.9	46.2	46.5	30	70	1.37:1 (16.1)
High Performance - Dual Polarized									
HPD2-11	10.7-11.7	2 (0.6)	3.4	34.0	34.3	34.4	30	55	1.37:1 (16.1)
HPLPD2-11	10.7-11.7	2 (0.6)	3.4	34.0	34.3	34.4	30	50	1.37:1 (16.1)
HPD3-11	10.7-11.7	3 (0.9)	2.2	37.2	37.4	37.6	30	62	1.37:1 (16.1)
HPD4-11	10.7-11.7	4 (1.2)	1.7	39.8	40.2	40.6	30	64	1.37:1 (16.1)
HPD6-11	10.7-11.7	6 (1.8)	1.1	42.9	43.2	43.6	30	66	1.37:1 (16.1)
HPD8-11	10.7-11.7	8 (2.4)	0.8	45.7	46.0	46.3	30	70	1.37:1 (16.1)
Standard Deep Reflector - Plane Polarized									
DP6-11	10.7-11.7	6 (1.8)	1.2	43.2	43.6	44.0	30	60	1.37:1 (16.1)
Standard Deep Reflector - Dual Polarized									
DPD6-11	10.7-11.7	6 (1.8)	1.2	43.0	43.4	43.8	30	55	1.37:1 (16.1)
Standard Parabolic - Plane Polarized									
SP2-11	10.7-11.7	2 (0.6)	3.4	34.3	34.6	34.9	30	40	1.37:1 (16.1)
SP3-11	10.7-11.7	3 (0.9)	2.6	37.5	37.7	37.9	30	44	1.37:1 (16.1)
SP4-11	10.7-11.7	4 (1.2)	1.7	40.2	40.5	40.9	30	46	1.37:1 (16.1)
SP6-11	10.7-11.7	6 (1.8)	1.1	43.3	43.6	44.0	30	50	1.37:1 (16.1)
SP8-11	10.7-11.7	8 (2.4)	0.8	46.1	46.3	46.7	30	52	1.37:1 (16.1)

All specifications subject to change without notice.

Radio Waves, Inc.

34 <http://www.radiowavesinc.com>

sales@radiowavesinc.com

ELECTRICAL SPECIFICATIONS- PARABOLIC ANTENNAS

10.7-11.7 GHz (CPR90G)

Model Number	Frequency, GHz	Diameter ft. (m)	3dB BW degs	Gain, dBi			XPD dB	F/B Ratio dB	VSWR, Max (R.L., dB)
				Low	Mid	High			
Standard Parabolic - Dual Polarized									
SPD2-11	10.7-11.7	2 (0.6)	3.4	34.1	34.4	34.7	30	40	1.37:1 (16.1)
SPD3-11	10.7-11.7	3 (0.9)	2.6	37.3	37.5	37.7	30	44	1.37:1 (16.1)
SPD4-11	10.7-11.7	4 (1.2)	1.7	40.0	40.3	40.7	30	46	1.37:1 (16.1)
SPD6-11	10.7-11.7	6 (1.8)	1.1	43.1	43.4	43.8	30	50	1.37:1 (16.1)
SPD8-11	10.7-11.7	8 (2.4)	0.8	45.9	46.1	46.5	30	52	1.37:1 (16.1)

12.70-13.25 GHz (WR75)

Model Number	Frequency, GHz	Diameter ft. (m)	3dB BW degs	Gain, dBi			XPD dB	F/B Ratio dB	VSWR, Max (R.L., dB)
				Low	Mid	High			
High Performance - Plane Polarized									
HPLP1-13	12.70-13.25	1 (0.3)	4.9	29.5	29.6	29.7	30	52	1.37:1 (16.1)
HP2-13	12.70-13.25	2 (0.6)	2.8	35.8	35.9	36.1	30	62	1.37:1 (16.1)
HP3-13	12.70-13.25	3 (0.9)	2.1	38.6	38.7	38.9	30	66	1.37:1 (16.1)
HP4-13	12.70-13.25	4 (1.2)	1.4	41.8	41.9	42.0	30	70	1.37:1 (16.1)
HP6-13	12.70-13.25	6 (1.8)	0.9	44.3	44.4	44.6	30	70	1.37:1 (16.1)
HP8-13	12.70-13.25	8 (2.4)	0.7	47.2	47.3	47.5	30	71	1.37:1 (16.1)
High Performance - Dual Polarized									
HPD2-13	12.70-13.25	2 (0.6)	2.8	35.0	35.1	35.3	30	62	1.37:1 (16.1)
HPD2-13	12.70-13.25	2 (0.6)	2.8	35.0	35.1	35.3	30	62	1.37:1 (16.1)
HPD3-13	12.70-13.25	3 (0.9)	2.1	38.4	38.5	38.7	30	66	1.37:1 (16.1)
HPD4-13	12.70-13.25	4 (1.2)	1.4	40.9	41.0	41.2	30	70	1.37:1 (16.1)
HPD6-13	12.70-13.25	6 (1.8)	0.9	44.1	44.2	44.4	30	70	1.37:1 (16.1)
HPD8-13	12.70-13.25	8 (2.4)	0.7	47.0	47.1	47.3	30	71	1.37:1 (16.1)
Standard Parabolic - Plane Polarized									
SP2-13*	12.70-13.25	2 (0.6)	2.8	35.2	35.3	35.5	30	44	1.37:1 (16.1)
SP3-13*	12.70-13.25	3 (0.9)	2.1	38.8	38.9	39.1	30	47	1.37:1 (16.1)
SP4-13*	12.70-13.25	4 (1.2)	1.4	41.2	41.3	41.5	30	49	1.37:1 (16.1)
SP6-13*	12.70-13.25	6 (1.8)	0.9	44.5	44.6	44.8	30	52	1.37:1 (16.1)
SP8-13*	12.70-13.25	8 (2.4)	0.7	47.4	47.5	47.7	30	54	1.37:1 (16.1)
Standard Parabolic - Dual Polarized									
SPD2-13*	12.70-13.25	2 (0.6)	2.8	35.1	35.2	35.4	30	44	1.37:1 (16.1)
SPD3-13*	12.70-13.25	3 (0.9)	2.1	38.6	38.7	38.9	30	47	1.37:1 (16.1)
SPD4-13*	12.70-13.25	4 (1.2)	1.4	41.1	41.2	41.4	30	49	1.37:1 (16.1)
SPD6-13*	12.70-13.25	6 (1.8)	1.9	44.3	44.4	44.6	30	52	1.37:1 (16.1)
SPD8-13*	12.70-13.25	8 (2.4)	0.7	47.2	47.3	47.5	30	54	1.37:1 (16.1)

* Requires an RD radome

14.25-15.35 GHz (WR62)

Model Number	Frequency, GHz	Diameter ft. (m)	3dB BW degs	Gain, dBi			XPD dB	F/B Ratio dB	VSWR, Max (R.L., dB)
				Low	Mid	High			
High Performance - Plane Polarized									
HPLP1-15	14.25-15.35	2 (0.6)	4.5	30.8	31.1	31.3	30	53	1.37:1 (16.1)
HP2-15	14.25-15.35	2 (0.3)	2.4	36.8	37.0	37.3	30	64	1.37:1 (16.1)
HP3-15	14.25-15.35	3 (0.9)	1.6	39.7	40.0	40.2	30	67	1.37:1 (16.1)
HP4-15	14.25-15.35	4 (1.2)	1.2	42.2	42.5	42.7	30	70	1.37:1 (16.1)
HP6-15	14.25-15.35	6 (1.8)	0.8	45.7	45.9	46.2	30	72	1.37:1 (16.1)
High Performance - Dual Polarized									
HPLPD1-15	14.25-15.35	1 (0.3)	4.5	30.0	30.9	31.1	30	53	1.37:1 (16.1)
HPD2-15	14.25-15.35	2 (0.6)	2.4	36.0	36.3	36.6	30	64	1.37:1 (16.1)
HPD3-15	14.25-15.35	3 (0.9)	1.6	39.5	39.8	40.0	30	67	1.37:1 (16.1)
HPD4-15	14.25-15.35	4 (1.2)	1.2	42.0	42.3	42.5	30	70	1.37:1 (16.1)
HPD6-15	14.25-15.35	6 (1.8)	0.8	45.2	45.5	45.7	30	72	1.37:1 (16.1)

ELECTRICAL SPECIFICATIONS- PARABOLIC ANTENNAS

17.7-19.7 GHz (WR42)

Model Number	Frequency, GHz	Diameter ft. (m)	3dB BW degs	Gain, dBi			XPD dB	F/B Ratio dB	VSWR, Max (R.L., dB)
				Low	Mid	High			
High Performance - Plane Polarized									
HPLP1-18	17.7-19.7	1 (0.3)	3.0	33.5	34.0	34.4	30	55	1.37:1 (16.1)
HP2-18	17.7-19.7	2 (0.6)	2.0	38.2	38.6	39.0	30	67	1.37:1 (16.1)
HP3-18	17.7-19.7	3 (0.9)	1.3	41.6	42.0	42.4	30	69	1.37:1 (16.1)
HP4-18	17.7-19.7	4 (1.2)	1.0	44.1	44.5	44.9	30	72	1.37:1 (16.1)
HP6-18	17.7-19.7	6 (1.8)	0.7	47.5	48.0	48.5	30	74	1.37:1 (16.1)
High Performance - Dual Polarized									
HPLPD1-18	17.7-19.7	1 (0.3)	3.0	33.3	33.8	34.2	30	55	1.37:1 (16.1)
HPD2-18	17.7-19.7	2 (0.6)	2.0	38.0	38.4	38.8	30	67	1.37:1 (16.1)
HPD3-18	17.7-19.7	3 (0.9)	1.3	41.4	41.8	42.2	30	69	1.37:1 (16.1)
HPD4-18	17.7-19.7	4 (1.2)	1.0	43.9	44.3	44.7	30	72	1.37:1 (16.1)
HPD6-18	17.7-19.7	6 (1.8)	0.7	47.3	47.8	48.3	30	74	1.37:1 (16.1)

21.2-23.6 GHz (WR42)

Model Number	Frequency, GHz	Diameter ft. (m)	3dB BW degs	Gain, dBi			XPD dB	F/B Ratio dB	VSWR, Max (R.L., dB)
				Low	Mid	High			
High Performance - Plane Polarized									
HPCPE-23	21.2-23.6	1 (0.3)	2.9	34.0	34.4	34.8	30	60	1.37:1 (16.1)
HPLP1-23	21.2-23.6	1 (0.3)	2.7	34.7	35.1	35.5	30	60	1.37:1 (16.1)
HP2-23	21.2-23.6	2 (0.6)	1.7	39.7	40.2	40.7	30	68	1.37:1 (16.1)
HP3-23	21.2-23.6	3 (0.9)	1.1	43.2	43.7	44.2	30	68	1.37:1 (16.1)
HP4-23	21.2-23.6	4 (1.2)	0.8	45.7	46.2	46.6	30	72	1.37:1 (16.1)
HP6-23	21.2-23.6	6 (1.8)	0.5	48.5	49.2	49.4	30	72	1.37:1 (16.1)
High Performance - Dual Polarized									
HPDCPE-23	21.2-23.6	1 (0.3)	2.9	33.8	34.2	34.6	30	60	1.37:1 (16.1)
HPLPD1-23	21.2-23.6	1 (0.3)	2.7	34.5	34.9	35.3	30	60	1.37:1 (16.1)
HPD2-23	21.2-23.6	2 (0.6)	1.7	39.5	40.0	40.5	30	68	1.37:1 (16.1)
HPD3-23	21.2-23.6	3 (0.9)	1.1	43.1	43.5	44.0	30	68	1.37:1 (16.1)
HPD4-23	21.2-23.6	4 (1.2)	0.8	45.4	46.0	46.4	30	72	1.37:1 (16.1)
HPD6-23	21.2-23.6	6 (1.8)	0.5	48.3	49.0	49.2	30	72	1.37:1 (16.1)

24.25-26.50 GHz (WR42)

Model Number	Frequency, GHz	Diameter ft. (m)	3dB BW degs	Gain, dBi			XPD dB	F/B Ratio dB	VSWR, Max (R.L., dB)
				Low	Mid	High			
High Performance - Plane Polarized									
HPCPE-26	24.25-26.50	1 (0.3)	2.6	35.3	35.7	35.9	30	62	1.37:1 (16.1)
HPLP1-26	24.25-26.50	1 (0.3)	2.5	35.7	36.1	36.5	30	62	1.37:1 (16.1)
HP2-26	24.25-26.50	2 (0.6)	1.4	40.7	41.1	41.5	30	69	1.37:1 (16.1)
HP3-26	24.25-26.50	3 (0.9)	1.0	44.2	44.6	45.0	30	72	1.37:1 (16.1)
HP4-26	24.25-26.50	4 (1.2)	0.7	46.5	46.9	47.2	30	74	1.37:1 (16.1)
High Performance - Dual Polarized									
HPLPD1-26	24.25-26.50	1 (0.3)	2.5	35.5	35.9	36.3	30	62	1.37:1 (16.1)
HPLPD2-26	24.25-26.50	2 (0.6)	1.4	40.5	40.9	41.3	30	66	1.37:1 (16.1)
HPLP2-26	24.25-26.50	2 (0.6)	1.4	40.7	41.1	41.5	30	66	1.37:1 (16.1)
HPD2-26	24.25-26.50	2 (0.6)	1.4	40.5	40.9	41.3	30	69	1.37:1 (16.1)
HPD3-26	24.25-26.50	3 (0.9)	1.0	44.0	44.4	44.8	30	72	1.37:1 (16.1)
HPD4-26	24.25-26.50	4 (1.2)	0.7	46.3	46.7	47.0	30	74	1.37:1 (16.1)

27.3-29.5 GHz (WR28)

Model Number	Frequency, GHz	Diameter ft. (m)	3dB BW degs	Gain, dBi			XPD dB	F/B Ratio dB	VSWR, Max (R.L., dB)
				Low	Mid	High			
High Performance - Plane Polarized									
HPCPE-28	27.3-29.5	1 (0.3)	2.2	35.8	36.1	36.3	30	64	1.37:1 (16.1)

27.3-31.3 GHz (WR28)

Model Number	Frequency, GHz	Diameter ft. (m)	3dB BW degs	Gain, dBi			XPD dB	F/B Ratio dB	VSWR, Max (R.L., dB)
				Low	Mid	High			
High Performance - Plane Polarized									
HPLP1-28	27.3-31.3	1 (0.3)	2.3	36.0	36.5	37.0	30	62	1.37:1 (16.1)
HP2-28	27.3-31.3	2 (0.6)	1.3	42.0	42.5	43.0	30	72	1.37:1 (16.1)
High Performance - Dual Polarized									
HPLPD1-28	27.3-31.3	1 (0.3)	2.3	35.8	36.3	36.8	30	62	1.37:1 (16.1)
HPD2-28	27.3-31.3	2 (0.6)	1.3	41.8	42.3	42.8	30	72	1.37:1 (16.1)

Radio Waves, Inc.

ELECTRICAL SPECIFICATIONS- PARABOLIC ANTENNAS

29.5-31.3 GHz (WR28)

Model Number	Frequency, GHz	Diameter ft. (m)	3dB BW degs	Gain, dBi			XPD dB	F/B Ratio dB	VSWR, Max (R.L., dB)
				Low	Mid	High			
High Performance - Plane Polarized									
HPCPE-31	29.5-31.3	1 (0.3)	2.1	36.3	36.6	36.8	30	64	1.37:1 (16.1)

31.3-33.4 GHz (WR28)

Model Number	Frequency, GHz	Diameter ft. (m)	3dB BW degs	Gain, dBi			XPD dB	F/B Ratio dB	VSWR, Max (R.L., dB)
				Low	Mid	High			
High Performance - Plane Polarized									
HPCPE-33	31.3-33.4	1 (0.3)	2.1	37.1	37.4	37.6	30	64	1.3:1 (17.7)
HPLP1-33	31.3-33.4	1 (0.3)	2.0	37.6	37.9	38.1	30	60	1.3:1 (17.7)
HPLPD1-33	31.3-33.4	1 (0.3)	2.0	37.4	37.7	37.9	30	60	1.3:1 (17.7)
HP2-33	31.3-33.4	2 (0.6)	1.2	42.6	42.9	43.1	30	72	1.3:1 (17.7)
HPD2-33	31.3-33.4	2 (0.6)	1.2	42.4	42.7	42.9	30	72	1.3:1 (17.7)

37.0-40.0 GHz (WR28)

Model Number	Frequency, GHz	Diameter ft. (m)	3dB BW degs	Gain, dBi			XPD dB	F/B Ratio dB	VSWR, Max (R.L., dB)
				Low	Mid	High			
High Performance - Plane Polarized									
HPCPE-38	37.0-40.0	1 (0.3)	1.8	38.5	38.7	38.9	30	64	1.3:1 (17.7)
HPLP1-38	37.0-40.0	1 (0.3)	1.7	39.0	39.3	39.7	30	60	1.37:1 (16.1)
HPLPD1-38	37.0-40.0	1 (0.3)	1.7	38.8	39.1	39.5	30	60	1.37:1 (16.1)
HP2-38	37.0-40.0	2 (0.6)	1.0	44.0	44.3	44.7	30	72	1.37:1 (16.1)
HPD2-38	37.0-40.0	2 (0.6)	1.7	43.8	44.1	44.5	30	72	1.37:1 (16.1)

57.0-64.0 GHz (WR15)

Model Number	Frequency, GHz	Diameter ft. (m)	3dB BW degs	Gain, dBi			XPD dB	F/B Ratio dB	VSWR, Max (R.L., dB)
				Low	Mid	High			
High Performance - Plane Polarized									
HPCPE-60	57.0-64.0	1 (0.3)	1.2	41.0	42.0	43.0	30	64	1.37:1 (16.1)
HP2-60	57.0-64.0	2 (0.6)	0.6	46.5	47.5	48.3	30	67	1.37:1 (16.1)

71.0 - 76.0 GHz (WR12)

Model Number	Frequency, GHz	Diameter ft. (m)	3dB BW degs	Gain, dBi			XPD dB	F/B Ratio dB	VSWR, Max (R.L., dB)
				Low	Mid	High			
High Performance - Plane Polarized									
HPCPE-73	71.0 - 76.0	1 (0.3)	1.0	43.5	44.0	44.5	30	64	1.37:1 (16.1)

71.0 - 86.0GHz (WR12)

Model Number	Frequency, GHz	Diameter ft. (m)	3dB BW degs	Gain, dBi			XPD dB	F/B Ratio dB	VSWR, Max (R.L., dB)
				Low	Mid	High			
High Performance - Plane Polarized									
HPCPE-80	71.0 - 86.0	1 (0.3)	0.9	43.0	43.8	44.6	30	64	1.37:1 (16.1)
HPLP2-80	71.0 - 86.0	2 (0.6)	0.4	50.0	51.0	52.0	30	66	1.37:1 (16.1)

PARABOLIC ANTENNA REGULATORY COMPLIANCES

5.925-6.425 GHz (CPR137G)

Antenna	FCC Compliance	ETSI Compliance
DP6-59	Part 101 Cat. A	ETS 300833 R1 C2
DPD6-59	Part 101 Cat. A	ETS 300833 R1 C2
HP4-59		ETS 300833 R1 C2
HP6-59	Part 101 Cat. A	ETS 300833 R1 C2
HP8-59	Part 101 Cat. A	ETS 300833 R1 C2
HPD4-59		ETS 300833 R1 C2
HPD6-59	Part 101 Cat. A	ETS 300833 R1 C2
HPD8-59	Part 101 Cat. A	ETS 300833 R1 C2
SP4-59		ETS 300833 R1 C1
SP6-59		ETS 300833 R1 C1
SP8-59	Part 101 Cat. B	ETS 300833 R1 C1
SPD4-59		ETS 300833 R1 C1
SPD6-59		ETS 300833 R1 C1
SPD8-59	Part 101 Cat. B	ETS 300833 R1 C1

6.425-7.125 GHz (CPR137G)

Antenna	FCC Compliance	ETSI Compliance
DP6-64	Part 101 Cat. A	ETS 300833 R1 C2
DPD6-64	Part 101 Cat. A	ETS 300833 R1 C2
HP4-64		ETS 300833 R1 C2
HP6-64	Part 101 Cat. A	ETS 300833 R1 C2
HP8-64	Part 101 Cat. A	ETS 300833 R1 C2
HPD4-64		ETS 300833 R1 C2
HPD6-64	Part 101 Cat. A	ETS 300833 R1 C2
HPD8-64	Part 101 Cat. A	ETS 300833 R1 C2
SP4-64		ETS 300833 R1 C1
SP6-64	Part 101 Cat. B	ETS 300833 R1 C1
SP8-64	Part 101 Cat. B	ETS 300833 R1 C1
SPD4-64		ETS 300833 R1 C1
SPD6-64	Part 101 Cat. B	ETS 300833 R1 C1

7.125-7.750 GHz (CPR112G)

Antenna	FCC Compliance	ETSI Compliance
HP2-7		ETS 300833 R1 C2
HP3-7		ETS 300833 R1 C2
HP4-7		ETS 300833 R1 C2
HP6-7		ETS 300833 R1 C2
HP8-7		ETS 300833 R1 C2
HPD2-7		ETS 300833 R1 C2
HPD3-7		ETS 300833 R1 C2
HPD4-7		ETS 300833 R1 C2
HPD6-7		ETS 300833 R1 C3
HPD8-7		ETS 300833 R1 C3
SP2-7		ETS 300833 R1 C1
SP3-7		ETS 300833 R1 C1
SP4-7		ETS 300833 R1 C1
SP6-7		ETS 300833 R1 C1
SP8-7		ETS 300833 R1 C1
SPD2-7		ETS 300833 R1 C1
SPD3-7		ETS 300833 R1 C1
SPD4-7		ETS 300833 R1 C1
SPD6-7		ETS 300833 R1 C1
SPD8-7		ETS 300833 R1 C1

7.125-8.5 GHz (CPR112G)

Antenna	FCC Compliance	ETSI Compliance
HP2-77*		ETS 300833 R1 C2
HP3-77		ETS 300833 R1 C2
HP4-77*		ETS 300833 R1 C2
HP6-77 *		ETS 300833 R1 C3
HP8-77		ETS 300833 R1 C2
HPD2-77		ETS 300833 R1 C2
HPD3-77		ETS 300833 R1 C2
HPD4-77		ETS 300833 R1 C2
HPD6-77		ETS 300833 R1 C3
HPD8-77		ETS 300833 R1 C2
SP2-77		ETS 300833 R1 C1
SP3-77		ETS 300833 R1 C1
SP4-77		ETS 300833 R1 C1
SP6-77		ETS 300833 R1 C1
SP8-77		ETS 300833 R1 C1
SPD2-77		ETS 300833 R1 C1
SPD3-77		ETS 300833 R1 C1
SPD4-77		ETS 300833 R1 C1
SPD6-77		ETS 300833 R1 C1
SPD8-77		ETS 300833 R1 C1

* ETSI class 3 versions available on special order

10.5-10.7 GHz (CPR90G)

Antenna	FCC Compliance	ETSI Compliance
HPCPE-10		
HPLP1-10		
HP2-10	Part 101 Cat. A	ETS 300833 R1 C2
HP3-10	Part 101 Cat. A	ETS 300833 R1 C2
HP4-10	Part 101 Cat. A	ETS 300833 R1 C2
HP6-10	Part 101 Cat. A	ETS 300833 R1 C2
HP8-10	Part 101 Cat. A	ETS 300833 R1 C3
HPD2-10	Part 101 Cat. A	ETS 300833 R1 C2
HPD3-10	Part 101 Cat. A	ETS 300833 R1 C2
HPD4-10	Part 101 Cat. A	ETS 300833 R1 C2
HPD6-10	Part 101 Cat. A	ETS 300833 R1 C3
HPD8-10	Part 101 Cat. A	ETS 300833 R1 C2
SP2-10		ETS 300833 R1 C1
SP3-10		ETS 300833 R1 C1
SP4-10	Part 101 Cat. B	ETS 300833 R1 C1
SP6-10	Part 101 Cat. B	ETS 300833 R1 C1
SP8-10	Part 101 Cat. B	ETS 300833 R1 C1
SPD2-10		ETS 300833 R1 C1
SPD3-10		ETS 300833 R1 C1
SPD4-10	Part 101 Cat. B	ETS 300833 R1 C1
SPD6-10	Part 101 Cat. B	ETS 300833 R1 C1
SPD8-10	Part 101 Cat. B	ETS 300833 R1 C1

10.5-11.7 GHz (CPR90G)

Antenna	FCC Compliance	ETSI Compliance
HPCPE-1011		
HPLP1-1011		
HP2-1011	Part 101 Cat. A*	ETS 300833 R1 C2
HP3-1011	Part 101 Cat. A*	ETS 300833 R1 C3
HP4-1011	Part 101 Cat. A	ETS 300833 R1 C2
HP6-1011	Part 101 Cat. A	ETS 300833 R1 C2
HP8-1011	Part 101 Cat. A	ETS 300833 R1 C3
HPD2-1011	Part 101 Cat. A*	ETS 300833 R1 C2
HPD3-1011	Part 101 Cat. A*	ETS 300833 R1 C2
HPD4-1011	Part 101 Cat. A	ETS 300833 R1 C2
HPD6-1011	Part 101 Cat. A	ETS 300833 R1 C2
HPD8-1011	Part 101 Cat. A	ETS 300833 R1 C3
SP2-1011		ETS 300833 R1 C1
SP3-1011		ETS 300833 R1 C1
SP4-1011	Part 101 Cat. B	ETS 300833 R1 C1
SP6-1011	Part 101 Cat. B	ETS 300833 R1 C1
SP8-1011	Part 101 Cat. B	ETS 300833 R1 C1
SPD2-1011		ETS 300833 R1 C1
SPD3-1011		ETS 300833 R1 C1
SPD4-1011	Part 101 Cat. B	ETS 300833 R1 C1
SPD6-1011	Part 101 Cat. B	ETS 300833 R1 C1
SPD8-1011	Part 101 Cat. B	ETS 300833 R1 C1

* 10 GHz band only

10.7-11.7 GHz (CPR90G)

Antenna	FCC Compliance	ETSI Compliance
HPCPE-11		
HPLP1-11		
HP2-11	Part 101 Cat. B	ETS 300833 R1 C2
HPLP2-11	Part 101 Cat. B	ETS 300833 R1 C2
HP3-11	Part 101 Cat. A	ETS 300833 R1 C3
HP4-11	Part 101 Cat. A	ETS 300833 R1 C2
HP6-11	Part 101 Cat. A	ETS 300833 R1 C2
HP8-11	Part 101 Cat. A	ETS 300833 R1 C3
HPD2-11	Part 101 Cat. B	ETS 300833 R1 C2
HPLPD2-11	Part 101 Cat. B	ETS 300833 R1 C2
HPD3-11	Part 101 Cat. A	ETS 300833 R1 C2
HPD4-11	Part 101 Cat. A	ETS 300833 R1 C2
HPD6-11	Part 101 Cat. A	ETS 300833 R1 C2
HPD8-11	Part 101 Cat. A	ETS 300833 R1 C3
SP2-11		ETS 300833 R1 C1
SP3-11		ETS 300833 R1 C1
SP4-11	Part 101 Cat. B	ETS 300833 R1 C1
SP6-11	Part 101 Cat. B	ETS 300833 R1 C1
SP8-11	Part 101 Cat. B	ETS 300833 R1 C1
SPD2-11		ETS 300833 R1 C1
SPD3-11		ETS 300833 R1 C1
SPD4-11	Part 101 Cat. B	ETS 300833 R1 C1
SPD6-11	Part 101 Cat. B	ETS 300833 R1 C1
SPD8-11	Part 101 Cat. B	ETS 300833 R1 C1

PARABOLIC ANTENNA REGULATORY COMPLIANCES

12.70-13.25 GHz (WR75)

Antenna	FCC Compliance	ETSI Compliance
HPLP1-13		ETS 300833 R1 C2
HP2-13		ETS 300833 R1 C2
HP3-13		ETS 300833 R1 C2
HP4-13	Part 101 Cat. B	ETS 300833 R1 C2
HP6-13	Part 101 Cat. A	ETS 300833 R1 C3
HP8-13	Part 101 Cat. A	ETS 300833 R1 C3
HPD2-13		ETS 300833 R1 C2
HPD3-13		ETS 300833 R1 C2
*HPD4-13	Part 101 Cat. B	ETS 300833 R1 C2
HPD6-13	Part 101 Cat. A	ETS 300833 R1 C3
HPD8-13	Part 101 Cat. A	ETS 300833 R1 C3
SP4-13	Part 101 Cat. B	ETS 300833 R1 C1
SP6-13	Part 101 Cat. B	ETS 300833 R1 C1
SP8-13	Part 101 Cat. B	ETS 300833 R1 C1
SPD4-13	Part 101 Cat. B	ETS 300833 R1 C1
SPD6-13	Part 101 Cat. B	ETS 300833 R1 C1
SPD8-13	Part 101 Cat. B	ETS 300833 R1 C1

14.25-15.35 GHz (WR62)

Antenna	FCC Compliance	ETSI Compliance
HPLP1-15		ETS 300833 R2 C2
HP2-15		ETS 300833 R2 C3
HP3-15		ETS 300833 R2 C2*
HP4-15		ETS 300833 R2 C3
HP6-15		ETS 300833 R2 C2
HPD2-15		ETS 300833 R2 C2
HPD3-15		ETS 300833 R2 C2
HPD4-15		ETS 300833 R2 C2

17.7-19.7 GHz (WR42)

Antenna	FCC Compliance	ETSI Compliance
HPLP1-18		ETS 300833 R2 C3
HP2-18	Part 101 Cat. A	ETS 300833 R2 C3
HP3-18	Part 101 Cat. A	ETS 300833 R2 C3
HP4-18	Part 101 Cat. A	ETS 300833 R2 C3
HP6-18	Part 101 Cat. A	ETS 300833 R2 C2
HPLPD1-18		ETS 300833 R2 C3
HPD2-18	Part 101 Cat. A	ETS 300833 R2 C3
HPD3-18	Part 101 Cat. A	ETS 300833 R2 C3
HPD4-18	Part 101 Cat. A	ETS 300833 R2 C3
HPD6-18	Part 101 Cat. A	ETS 300833 R2 C2

21.2-23.6 GHz (WR42)

Antenna	FCC Compliance	ETSI Compliance
HPCPE-23	Part 101 Cat. A	ETS 300833 R3 C3
HPLP1-23	Part 101 Cat. B	ETS 300833 R3 C3
HP2-23	Part 101 Cat. A	ETS 300833 R3 C3
HP3-23	Part 101 Cat. A	ETS 300833 R3 C3
HP4-23	Part 101 Cat. A	ETS 300833 R3 C3
HP6-23	Part 101 Cat. A	ETS 300833 R3 C2
HPLD1-23		ETS 300833 R3 C2
HPD2-23	Part 101 Cat. A	ETS 300833 R3 C3
HPD3-23	Part 101 Cat. A	ETS 300833 R3 C3
HPD4-23	Part 101 Cat. A	ETS 300833 R3 C3
HPD6-23	Part 101 Cat. A	ETS 300833 R3 C2

* ETSI Class 3 Version Available

24.25-26.50 GHz (WR42)

Antenna	FCC Compliance	ETSI Compliance
HPCPE-26	Part 101 Cat. A*	ETS 302217 R4 C3
HPLP1-26	Part 101 Cat. A*	ETS 302217 R4 C3
HPLP2-26	Part 101 Cat. A*	ETS 302217 R4 C3
HP2-26	Part 101 Cat. A*	ETS 302217 R4 C3
HP3-26	Part 101 Cat. A*	ETS 302217 R4 C3
HP4-26	Part 101 Cat. A*	ETS 302217 R4 C3
HPLPD1-26	Part 101 Cat. A*	
HPD2-26	Part 101 Cat. A*	ETS 302217 R4 C3
HPD3-26	Part 101 Cat. A*	ETS 302217 R4 C3
HPD4-26	Part 101 Cat. A*	ETS 302217 R4 C3
*24.25-25.25		

27.3-29.5 GHz (WR28)

Antenna	FCC Compliance	ETSI Compliance
HPCPE-28		ETS 300833 R4 C2

27.3-31.3 GHz (WR28)

Antenna	FCC Compliance	ETSI Compliance
HPLP1-28		ETS 300833 R5 C1
HP2-28		ETS 300833 R5 C1
HPLPD1-28		ETS 300833 R5 C1
HPD2-28		ETS 300833 R5 C1

29.5-31.3 GHz (WR28)

Antenna	FCC Compliance	ETSI Compliance
HPCPE-31		ETS 300833 R5

31.3-31.9 GHz (WR28)

Antenna	FCC Compliance	ETSI Compliance
HPCPE-32		ETS 300833 R5 C1
HP2-32		ETS 300833 R5 C1

31.3 - 33.4 GHz (WR28)

Antenna	FCC Compliance	ETSI Compliance
HPCPE-33		ETS 300833 R5 C1
HPLP1-33		ETS 300833 R5 C1
HP2-33		ETS 300833 R5 C1
HPLPD1-33		ETS 300833 R5 C1
HPD2-33		ETS 300833 R5 C1

37.0-40.0 GHz (WR28)

Antenna	FCC Compliance	ETSI Compliance
HPCPE-38	Part 101 Cat. A	ETS 300833 R5 C3
HPLP1-38	Part 101 Cat. A	ETS 300833 R5 C3
HPLPD1-38	Part 101 Cat. A	ETS 300833 R5 C3
HP2-38	Part 101 Cat. A	ETS 300833 R5 C3
HPD2-38	Part 101 Cat. A	ETS 300833 R5 C3

57.0-64.0 GHz (WR15)

Antenna	FCC Compliance	ETSI Compliance
HPCPE-60		ETS 300833 R6 C2

71.0-76.0 GHz (WR12)

Antenna	FCC Compliance	ETSI Compliance
HPCPE-73	Part 101 Cat. A	ETS 302217 R7

71.0 - 86.0 GHz (WR12)

Antenna	FCC Compliance	ETSI Compliance
HPCPE- 80	Part 101 Cat. A	ETS 302217 R7
HPLP2-80	Part 101 Cat. A	ETS 302217 R7

ANTENNA DIMENSIONS (DETAIL)

SEC AND PRO-VIDER SERIES

SEC-5V-120-14
SEC-5V-120-16

All other sectors

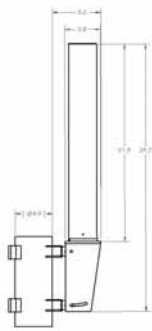

Side View



Back View

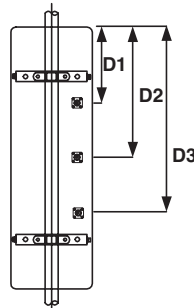

Rear View

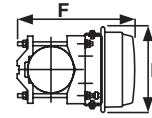

Top View

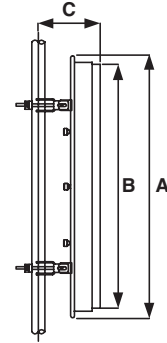

Side View

*Dimensions = Inches/cm.

Model	A	B	C	D1	D2	D3	E	F
25.5 in. pkg	25.5 (64.8)	23.5 (59.7)	7.5 (19.1)	—	12.8 (32.5)	—	8.5 (21.6)	10.5 (26.7)
41.5 in. pkg	41.5 (105.4)	39.5 (100.3)	7.5 (19.1)	9.5 (24.1)	21.5 (54.6)	31.5 (80.0)	8.5 (21.6)	10.5 (26.7)

Based on 4.5 inches (11.4 cm) pipemast. Mount designed to attach to pipemast between $2.0 \leq (5.1 \text{ cm})$ and $4.5 \leq (11.4 \text{ cm})$.

ANTENNA DIMENSIONS (DETAIL)

FLAT PANEL SERIES & XCELERATOR

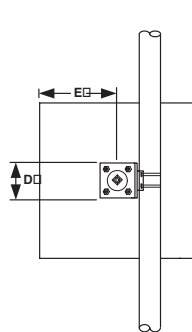

Rear View



Side View

*Dimensions = Inches/cm.

Model	A	B	C	D	E
FP5-5-18	6.0 (15.2)	0.5 (1.3)	5.0 (12.7)	4.7 (12.0)	3.0 (7.6)
FP1-3-18	12.0 (30.0)	0.5 (1.3)	5.0 (12.7)	4.7 (12.0)	6.0 (15.2)
FP1-5-24	12.0 (30.0)	0.5 (1.3)	5.0 (12.7)	4.7 (12.0)	6.0 (15.2)
FP2-5-28	24.0 (61.0)	0.5 (1.3)	5.0 (12.7)	4.7 (12.0)	12.0 (30.5)
FPD.5-5-18	6.0 (15.2)	0.5 (1.3)	5.0 (12.7)	4.7 (12.0)	3.0 (7.6)

Mount designed to attach to pipemast between $2.0 \leq (5.1 \text{ cm})$ and $2.5 \leq (\text{___} \text{ cm})$.

Radio Waves, Inc.

40 <http://www.radiowavesinc.com>

sales@radiowavesinc.com

ANTENNA DIMENSIONS (DETAIL)

G3 SERIES 3' (0.9M)

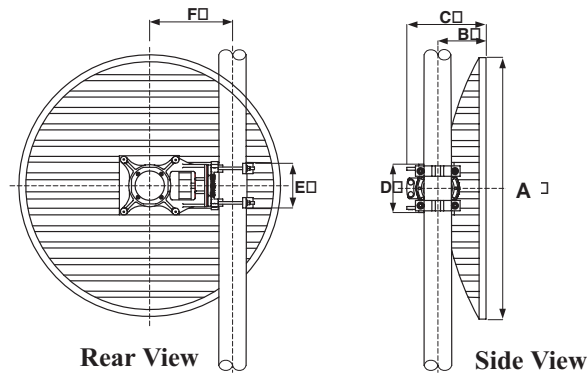

*Dimensions = Inches/cm

Diameter	A	B	C	D	E	F
3 ft (0.9m)	37.0 (94.0)	10.0 (25.4)	9.3 (23.6)	7.0 (17.8)	6.0 (15.2)	12.3 (31.2)

Adjustment Ranges:

Azimuth: Coarse 360° **Elevation:** Fine +/-10°

Based on 4.5 inches (11.4 cm) pipemast. Mount designed to attach to pipemast 2.0" (5.1 cm) and 4.5" (11.4 cm).

G4 SERIES: 4' (1.2M) & 6' (1.8M)

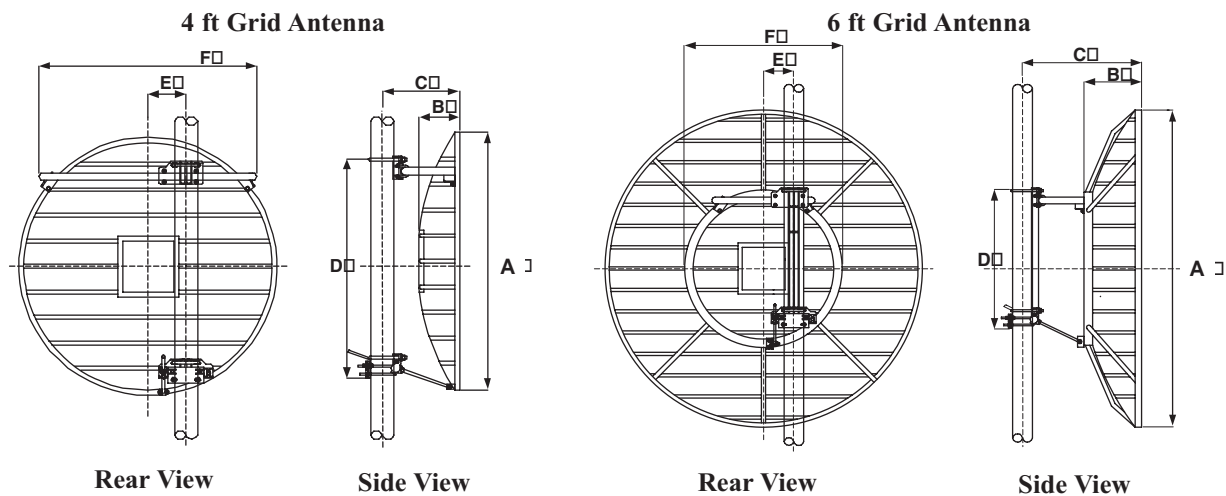

Diameter	A	B	C	D	E	F
4 ft (1.2m)	50.5 (128.3)	13.0 (33.0)	12.2 (31.0)	36.0 (91.4)	7.0 (17.8)	44.5 (113.0)
6 ft (1.8m)	74.5 (189.2)	13.5 (34.3)	27.7 (70.4)	21.0 (53.3)	7.0 (17.8)	36.0 (91.4)

Adjustment Ranges:

Azimuth: Coarse 360° **Elevation:** Fine +/-25°

Fine +/-10°

Based on 4.5 inches (11.4 cm) pipemast. Mount designed to attach to pipemast 4.5" (11.4 cm).

*Dimensions = Inches/cm

ANTENNA DIMENSIONS (DETAIL)

HP SERIES: HPLP1' (0.3M), HPCPE 1' (0.3M) & HP2 (0.6M)

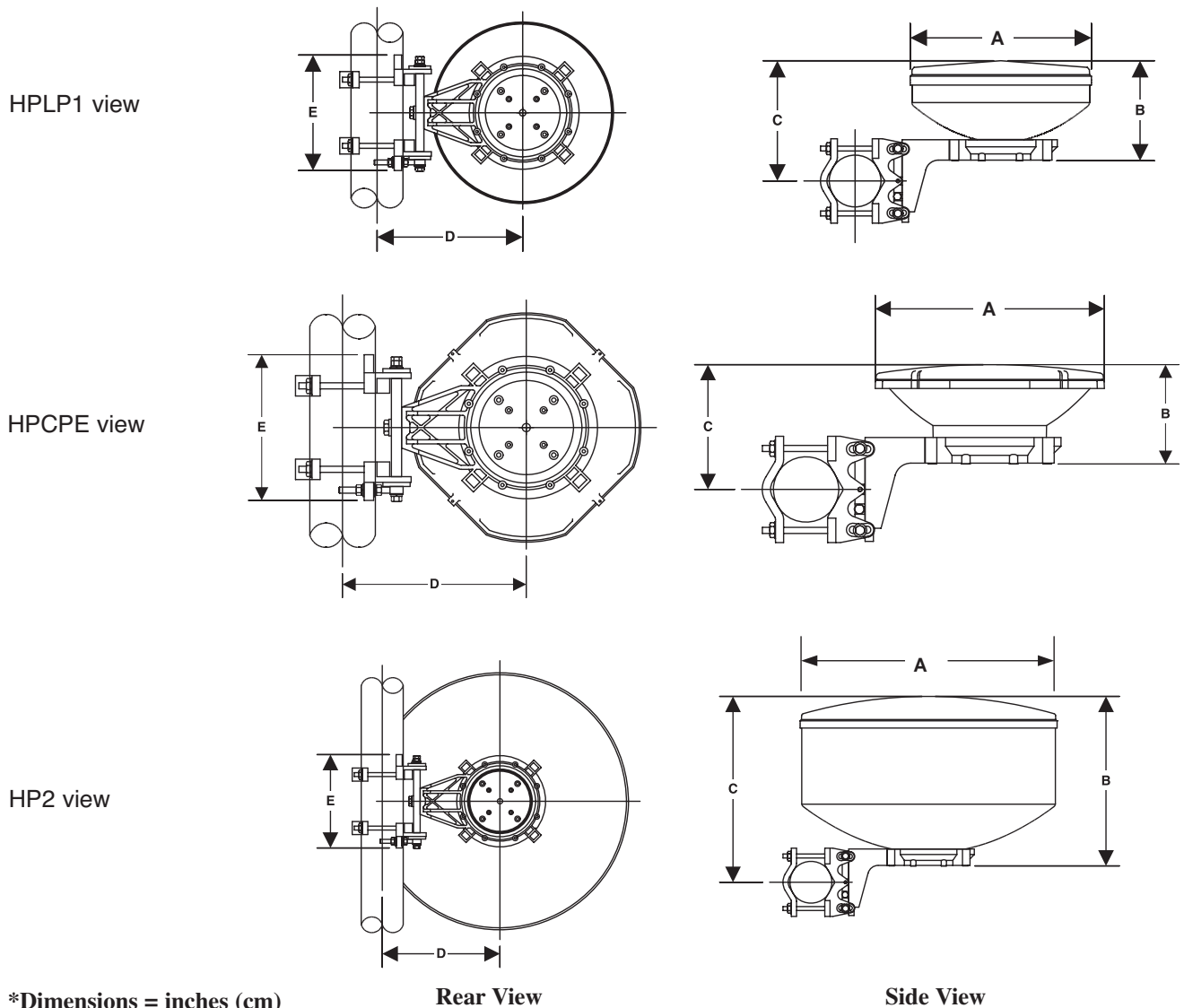

*Dimensions = inches (cm)

Diameter	A	B	C	D	E
HPLP1 (0.3m)	13.0 (33.0)	6.1 (15.5)	7.6 (19.3)	11.2 (28.4)	8.9 (22.6)
HPCPE (0.3m)	13.9 (35.3)	7.7 (19.6)	9.3 (23.6)	11.2 (28.4)	8.9 (22.6)
HP2 (0.6m)	24.5 (62.2)	16.2 (41.1)	17.7 (44.9)	11.2 (28.4)	8.9 (22.6)

Adjustment Ranges:

Azimuth:	Coarse	360°	Elevation:	Fine	+/-30°
	Fine	+/-10°			

Mount designed to attach to pipemast between 2.0" (51 mm) and 4.5" (114 mm).

ANTENNA DIMENSIONS (DETAIL)

HP SERIES: 3' (0.9M), 4' (1.2M), 6' (1.80M) & 8' (2.40M)

3' and 4' views

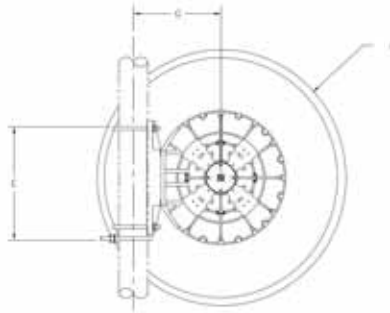

Rear View

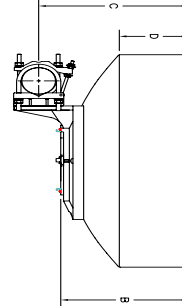

Side View

6' view

8' view

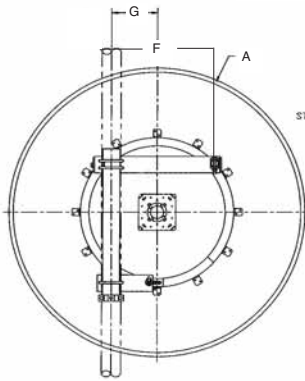

Rear View

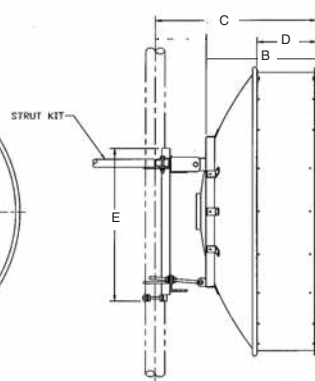

Side View

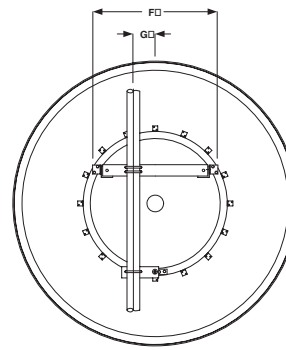

Rear View

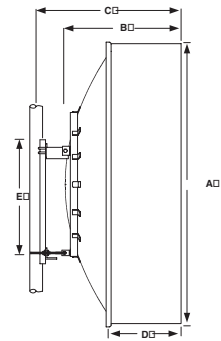

Side View

*Dimensions = inches (cm)

Diameter	A	B	C	D	E	F	G
3 ft (0.9m)	38.0 (96.5)	17.1 (43.4)	20.1 (51.0)	9.3 (23.6)	17.0 (43.1)	N/A	13.4 (34.0)
4 ft (1.2m)	50.0 (127.0)	25.2 (64.0)	28.1 (71.4)	16.0 (40.6)	17.0 (43.1)	N/A	13.4 (34.0)
6 ft (1.8m)	70.0 (177.8)	26.0 (66.0)	38.0 (96.5)	14.0 (35.5)	21.0 (53.3)	29.5 (74.9)	11.0 (27.9)
8 ft (2.4m)	99.3 (252.2)	46.0 (116.8)	58.0 (147.3)	32.0 (81.3)	44.3 (112.5)	44.0 (111.8)	7.0 (17.8)

Adjustment Ranges:

Azimuth: Coarse 360° **Elevation:** Fine +/--10° (+/--5° 8 ft model only)
 Fine +/--10° (+/--5° 8 ft model only)

Dimensions based on 4.5" (11.4 cm) pipemast. Mount designed to attach to a 4.5" (11.4 cm) vertical pipemast.

ANTENNA DIMENSIONS (DETAIL)

SP SERIES: 1' (0.3M) & 2' (0.6M)

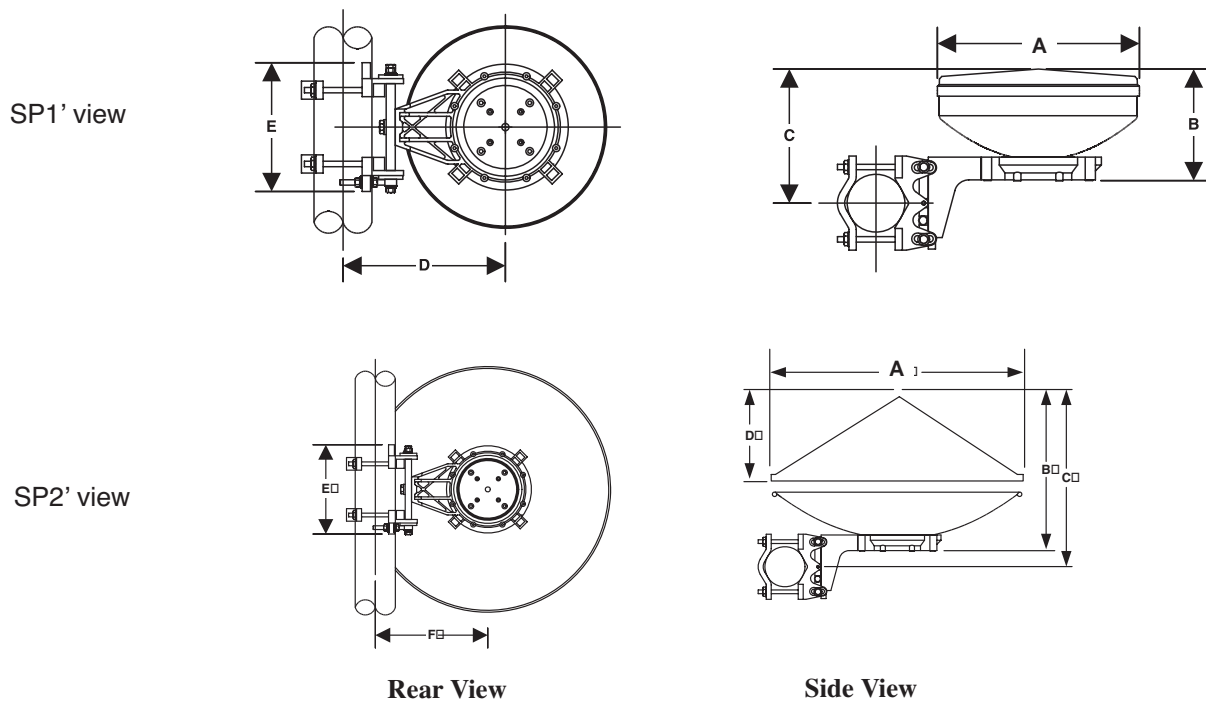

*Dimensions = Inches/cm

Diameter	A	B	C	D	E	F
1 ft (0.3m)	13.5 (34.3)	5.4 (13.7)	9.2 (23.4)	3.2 (8.0)	8.3 (21.1)	3.8 (9.7)
2 ft (0.6m)	25.3 (64.1)	10.9 (27.7)	13.7 (34.8)	5.8 (14.7)	8.9 (22.6)	11.2 (28.4)

Adjustment Ranges:

Azimuth:	Coarse	360°	Elevation:	Fine	+/-40°
	Fine	+/-10°			

Based on 4.5 inches (11.4 cm) pipemast. Mount designed to attach to pipemast between 2.0" (5.08 cm) and 4.5" (11.4 cm).

ANTENNA DIMENSIONS (DETAIL)

SP SERIES: 3' (0.9M), 4' (1.2M), 6' (1.8M) & 8' (2.4M)

3', 4', 6' views

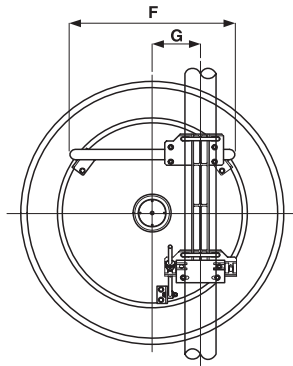

Rear View

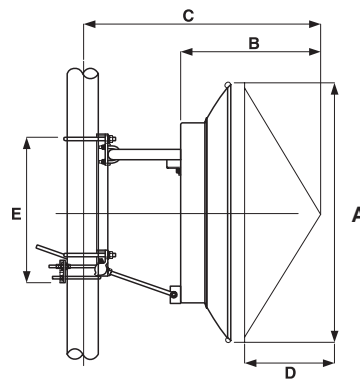

Side View

8' view

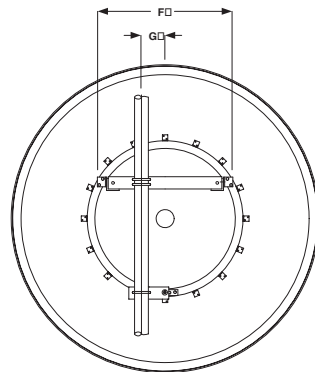

Rear View

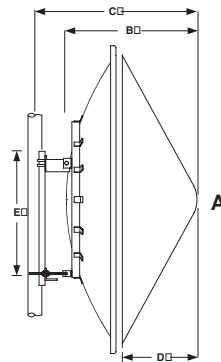

Side View

*Dimensions = Inches/cm

Diameter	A	B	C	D	E	F	G
3 ft (0.9m)	38.0 (91.4)	19.7 (49.9)	30.9 (78.5)	9.8 (24.9)	21.1 (53.3)	25.7 (65.3)	7.0 (17.8)
4 ft (1.2m)	50.5 (128.3)	21.4 (54.4)	35.6 (90.4)	13.1 (33.3)	21.1 (53.3)	25.7 (65.3)	7.0 (17.8)
6 ft (1.8m)	70.0 (177.8)	26.9 (68.3)	41.1 (104.4)	13.8 (35.1)	21.1 (53.3)	25.7 (65.3)	7.0 (17.8)
8 ft (2.4m)	99.3 (252.2)	46.0 (116.8)	58.0 (147.3)	24.5 (62.2)	44.3 (112.5)	44.0 (111.8)	7.0 (17.8)

Adjustment Ranges:

Azimuth: Coarse 360° **Elevation:** Fine +/-25° (+/-5° 8 ft model only)

Fine +/-10° (+/-5° 8 ft model only)

Based on 4.5 inches (11.4 cm) pipemast. Mount designed to attach to a 4.5" (11.4cm) vertical pipemast.

ANTENNA WIND FORCES AND LOADS

60° & 90° SECTOR ANTENNAS

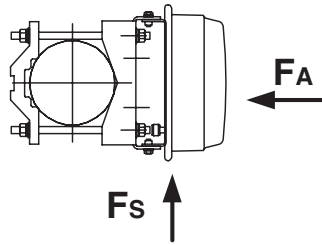

Top View

*Dimensions = Inches/cm.

Antenna Windloading 25.5 in pkg		41.5 in pkg	
Fa max	85 lbs., (378N)	Fa max	139 lbs., (619N)
Fs max	32 lbs., (142N)	Fs max	48 lbs., (214N)

Loading applied to tower at survival windspeed of 125 mph (210km/h)

ANTENNA WIND FORCES AND LOADS

FLAT PANEL SERIES .5' (0.15M), 1' (0.3M) & 2' (0.6M)

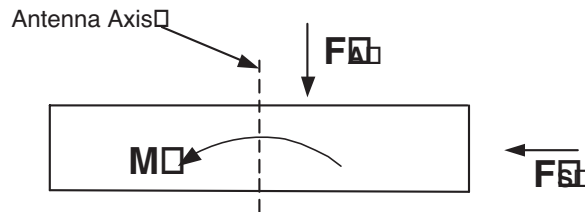

Top View

*Dimensions = Inches/cm

Antenna Windloading FP Series .5' (0.15m)			
Fa max	14 lbs. (62N)	MT max	0 lbs. (0N)
Fs max	0 lbs. (0N)		

Antenna Windloading FP Series 1' (0.3m)			
Fa max	49 lbs. (220N)	MT max	0 lbs. (0N)
Fs max	0 lbs. (0N)		

Antenna Windloading FP Series 2' (0.6m)			
Fa max	202 lbs. (905N)	MT max	0 lbs. (0N)
Fs max	0 lbs. (0N)		

ANTENNA WIND FORCES AND LOADS

G3, G4 & G6 SERIES

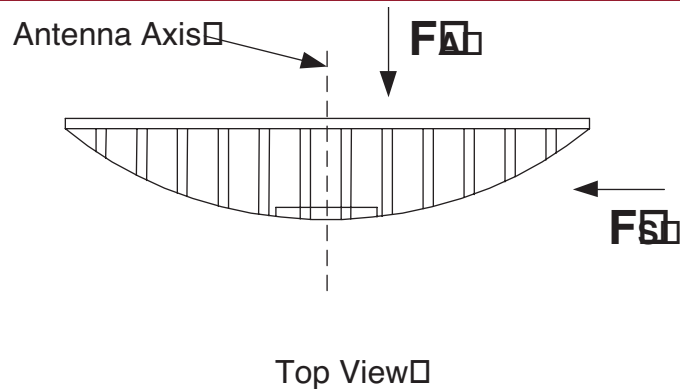

*Dimensions = Inches/cm

Antenna Windloading G3 Series 3' (0.9m)

Fa max	140 lbs. (623N)
Fs max	43 lbs. (191N)

Antenna Windloading G4 Series 4' (1.2m)

Fa max	395 lbs. (1758N)
Fs max	147 lbs. (654N)

Antenna Windloading G6 Series 6' (1.8m)

Fa max	701 lbs. (3119N)
Fs max	303 lbs. (1348N)

Loading applied to tower at survival windspeed of 125 mph (210km/h)

ANTENNA WIND FORCES AND LOADS

HP & SP SERIES

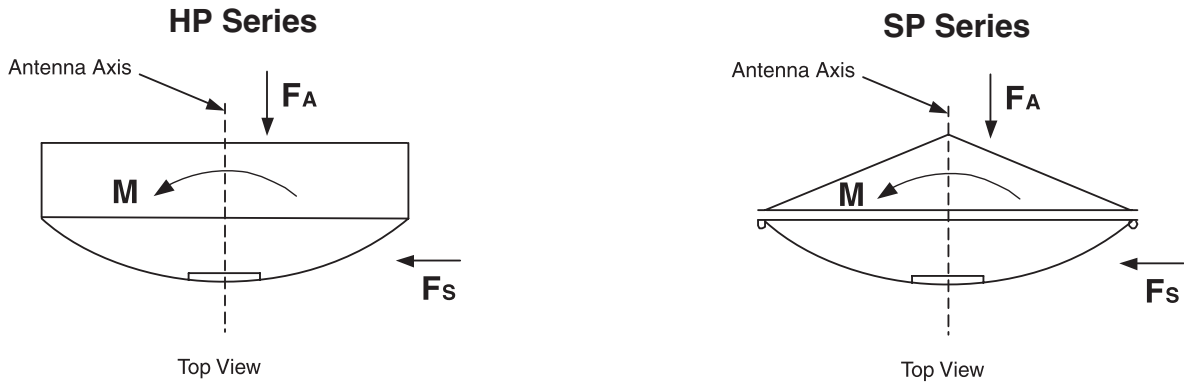

*Dimensions = Inches/cm

Antenna Windloading		1' (0.3m) (HPLP1 & HPCPE)		2' (0.6m)		3' (90 cm)	
Fa Max	46 lbs. (204N)	Fa max	202 lbs. (899N)	Fa max	403 lbs. (1792N)		
Fs Max	13 lbs. (58N)	Fs max	100 lbs. (445N)	Fs max	200 lbs. (890N)		
MT Max	27 ft-lbs. (36N)	MT max	194 ft-lbs. (263Nm)	MT max	344 ft-lbs. (466Nm)		

SP Series Windloading

	Without Radome		Without Radome		
Fa Max	46 lbs. (204N)	Fa max	222 lbs. (988N)	Fa max	492 lbs. (2189N)
Fs Max	13 lbs. (58N)	Fs max	14 lbs. (62N)	Fs max	40 lbs. (178N)
		MT max	225 lbs. (305Nm)	MT max	545 lbs. (739Nm)
	With Radome		With Radome		
		Fa max	122 lbs. (543N)	Fa max	271 lbs. (1206N)
		Fs max	24 lbs. (107N)	Fs max	64 lbs. (285N)
		MT max	194 ft-lbs. (263Nm)	MT max	394 ft-lbs. (534Nm)

Antenna Windloading		4' (1.2m)		6' (1.8m)		8' (2.4m)	
Fa max	737 lbs. (3278N)	Fa max	1680 lbs. (7473N)	Fa max	2773 lbs. (12334N)		
Fs max	365 lbs. (1623N)	Fs max	832 lbs. (3700N)	Fs max	1422 lbs. (6325N)		
MT Max	784 ft-lbs. (1063Nm)	MT max	2100 ft-lbs. (2847Nm)	MT max	4400 ft-lbs. (5965Nm)		

SP Series Windloading

	Without Radome		Without Radome		Without Radome	
Fa max	855 lbs. (3803N)	Fa max	1768 lbs. (7865N)	Fa max	3795 lbs. (16940N)	
Fs max	45 lbs. (200N)	Fs max	98 lbs. (436N)	Fs max	1115 lbs. (4980N)	
MT Max	1120 ft-lbs. (1518Nm)	MT max	2270 ft-lbs. (3077Nm)	MT max	4800 ft-lbs. (6508Nm)	
	With Radome		With Radome		With Radome	
Fa max	469 lbs. (2087N)	Fa max	973 lbs. (4329N)	Fa max	2773 lbs. (12334N)	
Fs max	93 lbs. (414N)	Fs max	162 lbs. (721N)	Fs max	1422 lbs. (6325N)	
MT max	784 ft-lbs. (1063Nm)	MT max	2100 ft-lbs. (2847Nm)	MT max	4400 ft-lbs. (5966Nm)	

Loading applied to tower at survival windspeed of 125 mph (210km/h)

Please see Page 49 for information on Side Struts.

SIDE STRUTS

Side Struts are devices which help to increase antenna stability under high wind conditions. Radio Waves manufactures and highly recommends the usage of additional side struts to enhance the wind survival of microwave antennas. Side struts are an economical and efficient way to improve the wind survival rating of Radio Waves high quality microwave antennas. Radio Waves standard parabolic and high performance antennas have a wind survival rating of 125 mph (201 km/h) in their normal configuration. The SP8, HP6 and HP8 series include one side strut with the standard antenna package to achieve these levels of wind survival.

To achieve a wind survival rating of 150 mph (241 km/h) please use the appropriate side strut selection table to purchase an additional side strut as noted below:

Antenna Size	Model Number
SP2, HP2	SST-2/3
SP3, HP3	SST-2/3
SP4, HP4	SST-4/6
SP6, HP6	SST-4/6
SP8, HP8	SST-8

For extreme high wind conditions the Radio Waves SP2 series can be utilized with an RD2 conical radome and an SST-2/3 to achieve a wind survival rating of 200 mph (332 km/h).

For further information or installation recommendations for Side Struts please contact Radio Waves technical support.



ELLIPTICAL WAVEGUIDE

Introduction:

Radio Waves offers an elliptical waveguide, which is the premium choice for 5.85-13 GHz range microwave antenna transmission line systems where the radios are mounted indoors. The elliptical waveguide manufacturing process is continuous, so waveguide can be supplied in long lengths. The waveguide is constructed of highly conductive copper, which uses a special process to corrugate and form into an elliptical shape. The copper waveguide is then covered with a black polyethylene jacket for protection that makes the cable rugged and resistant to the full range of outdoor environmental conditions, as well as installation and transportation. The waveguide can be supplied cut to length with factory-attached connectors, or supplied in continuous lengths for termination at the site.

Installation and Service:

Corrugated walls allow the waveguide to offer high crush strength, extreme flexibility, and a low weight for superior handling and forming during the installation process. The copper walls and black polyethylene coating allow for a long service life, which translates into a cost effective system performance.

Elliptical Waveguide Selection:

Radio Waves offers two types of elliptical waveguide, ranging from 5.85 GHz to 13 GHz frequency bands. The standard elliptical waveguide is equivalent to the rectangular waveguide, WR137 to WR75. The standard waveguide connectors mate with popular MIL, EIA and IEC flanges. Standard waveguide connectors are non-tunable.

One Stop Shopping + Less Planning = Saves Cost:

In addition to elliptical waveguide, Radio Waves offers a complete line of waveguide connectors and installation accessory items for use with the elliptical waveguide, as well as dehydrators and pressurization equipment. Radio Waves has the experience, so let us help coordinate your next system!

ELLIPTICAL WAVEGUIDE

5.85-7.125 GHz

RWE63

Structure

Description	Elliptical corrugated copper tube
Jacket/Thickness, mm(in)	UV Resistant black polyethylene/1.8 (0.07)
Dimension over Jacket, mm (in)	51.5 x 30.6 (2.03 x 1.20)

Mechanical Specifications

Weight, kg/m (lb/ft)	0.84 (0.56)
Minimum Bending Radius E Plane, without rebending, mm (in)	200 (7.9)
Minimum Bending Radius H Plane, without rebending, mm (in)	500 (19.7)
Minimum Bending Radius E Plane, with rebending, mm (in)	700 (11.8)
Minimum Bending Radius H Plane, with rebending, mm (in)	700 (27.6)
Maximum Twist, degree/m (degree/ft)	3 (1.0)
Max. Operating Pressure, bar (psi)	0.5 (7.3)
Max. Pulling Length per Hoisting Grip, m (ft)	60 (197)
Standard Hanger Spacing, m (ft)	1 (3)
Recommended Installation Temperature Range, °C (°F)	-20 to +60 (-4 to +140)
Recommended operation temperature range, °C (°F)	-40 to +80 (-40 to +176)



Electrical Specifications

Cut-off Frequency, GHz	4.1
Frequency Range, GHz	5.85 - 7.125
Max. VSWR / Return Loss, dB	1.03/36.61

VSWR values include connectors and are valid for frequency band of connectors.

RWE63 Attenuation, Average Power, Group Velocity

Frequency GHz	Attenuation dB/100 m (ft)	Avg. Pow. kW	Group Vel. %c
5.0	5.80 (1.76)		
5.2	5.41 (1.64)		
5.4	5.05 (1.50)		
5.6	4.81 (1.47)		
5.8	4.62 (1.41)		
5.9	4.58 (1.40)	4.61	70.2
6.0	4.51 (1.37)	4.69	71.4
6.1	4.44 (1.35)	4.76	72.5
6.2	4.38 (1.33)	4.83	73.6
6.3	4.32 (1.32)	4.90	74.5
6.4	4.27 (1.30)	4.96	75.5
6.5	4.22 (1.29)	5.01	76.3
6.6	4.17 (1.27)	5.07	77.1
6.7	4.13 (1.26)	5.12	77.9
6.8	4.09 (1.25)	5.17	78.6
6.9	4.06 (1.24)	5.21	79.3
7.0	4.03 (1.23)	5.25	80.0
7.1	3.99 (1.22)	5.30	80.6

Standard Conditions:
For attenuation: VSWR 1.0, ambient temperature 20° C (68° F).
For average power: VSWR 1.0 and 82° C (180°) F inner temperature 40° C (140° F) ambient.

**RWC137-063, FIXED
CONN. RWE63,
CPR137G**

ELLIPTICAL WAVEGUIDE

7.12-8.5 GHz

RWE77

Structure

Description	Elliptical corrugated copper tube
Jacket/Thickness, mm(in)	UV Resistant black polyethylene/1.4 (0.06)
Dimension over Jacket, mm (in)	43.7 x 25.5 (1.72 x 1.0)

Mechanical Specifications

Weight, kg/m (lb/ft)	0.7 (0.47)
Minimum Bending Radius E Plane, without rebending, mm (in)	200 (7.9)
Minimum Bending Radius H Plane, without rebending, mm (in)	500 (19.7)
Minimum Bending Radius E Plane, with rebending, mm (in)	250 (9.8)
Minimum Bending Radius H Plane, with rebending, mm (in)	600 (23.6)
Maximum Twist, degree/m (degree/ft)	3 (1.0)
Max. Operating Pressure, bar (psi)	0.5 (7.3)
Max. Pulling Length per Hoisting Grip, m (ft)	60 (197)
Standard Hanger Spacing, m (ft)	1.0 (3)
Recommended Installation Temperature Range, °C (°F)	-20 to +60 (-4 to +140)
Recommended operation temperature range, °C (°F)	-40 to +80 (-40 to +176)



Electrical Specifications

Cut-off Frequency, GHz	5.0
Frequency Range, GHz	7.125-8.5
Max. VSWR / Return Loss, dB	1.03/36.61

VSWR values include connectors and are valid for frequency band of connectors.

RWE77 Attenuation, Average Power, Group Velocity

Frequency GHz	Attenuation dB/100 m (ft)	Avg. Pow. kW	Group Vel. %c
7.1	6.65 (2.03)	2.88	71.0
7.2	6.56 (2.00)	2.92	72.0
7.3	6.48 (1.97)	2.96	72.9
7.4	6.40 (1.95)	2.99	73.7
7.5	6.33 (1.93)	3.03	74.5
7.6	6.27 (1.91)	3.06	75.3
7.7	6.21 (1.89)	3.09	76.0
7.8	6.15 (1.87)	3.12	76.8
7.9	6.10 (1.86)	3.14	77.4
8.0	6.05 (1.84)	3.17	78.1
8.1	6.00 (1.83)	3.20	78.7
8.2	5.96 (1.82)	3.22	79.3
8.3	5.91 (1.80)	3.24	79.8
8.4	5.87 (1.79)	3.26	80.4
8.5	5.84 (1.78)	3.28	80.9

Standard Conditions:
For attenuation: VSWR 1.0, ambient temperature 20° C (68° F).
For average power: VSWR 1.0 and 82° C (180°) F inner temperature 40° C (140°) F ambient.

**RWC112-077, FIXED
CONN. FOR RWE77,
CPR112G**

ELLIPTICAL WAVEGUIDE

10.2-11.7 GHz

RWE90

Structure

Description	Elliptical corrugated copper tube
Jacket/Thickness, mm(in)	UV Resistant black polyethylene/1.3 (0.05)
Dimension over Jacket, mm (in)	32.8 x 19.7 (1.29 x 0.78)

Mechanical Specifications

Weight, kg/m (lb/ft)	0.5 (0.34)
Minimum Bending Radius E Plane, without rebending, mm (in)	150 (5.9)
Minimum Bending Radius H Plane, without rebending, mm (in)	300 (11.8)
Minimum Bending Radius E Plane, with rebending, mm (in)	200 (7.9)
Minimum Bending Radius H Plane, with rebending, mm (in)	500 (19.7)
Maximum Twist, degree/m (degree/ft)	3 (1.0)
Max. Operating Pressure, bar (psi)	0.5 (7.3)
Max. Pulling Length per Hoisting Grip, m (ft)	60 (197)
Standard Hanger Spacing, m (ft)	1.0 (3)
Recommended Installation Temperature Range, °C (°F)	-20 to +60 (-4 to +140)
Recommended operation temperature range, °C (°F)	-40 to +80 (-40 to +176)



Electrical Specifications

Cut-Off Frequency, GHz	6.75
Frequency Range, GHz	10.2-11.7
Max. VSWR / Return Loss, dB	1.03/36.61

VSWR values include connectors and are valid for frequency band of connectors.

RWE90 Attenuation, Average Power, Group Velocity

Frequency GHz	Attenuation dB/100 m (ft)	Avg. Pow. kW	Group Vel. %c
10.2	10.08 (3.07)	1.58	75.0
10.3	10.01 (3.05)	1.59	75.5
10.4	9.94 (3.03)	1.60	76.1
10.5	9.87 (3.01)	1.61	76.6
10.6	9.81 (2.99)	1.62	77.1
10.7	9.74 (2.97)	1.63	77.6
10.8	9.68 (2.95)	1.64	78.1
10.9	9.63 (2.93)	1.65	78.5
11.0	9.57 (2.92)	1.66	79.0
11.1	9.47 (2.89)	1.67	79.4
11.2	9.43 (2.87)	1.68	79.8
11.3	9.38 (2.86)	1.69	80.2
11.4	9.34 (2.85)	1.70	80.6
11.5	9.30 (2.83)	1.70	81.0
11.6	9.26 (2.82)	1.71	81.3

Standard Conditions:

For attenuation: VSWR 1.0, ambient temperature 20° C (68° F).

For average power: VSWR 1.0 and 82° C (180°) F inner temperature 40° C (140° F) ambient.

**RWC90-090, FIXED
CONN. FOR RWE90,
CPR90G**

ELLIPTICAL WAVEGUIDE

11.7-13.25 GHz

RWE127

Structure

Description	Elliptical corrugated copper tube
Jacket/Thickness, mm(in)	UV Resistant black polyethylene/1.3 (0.05)
Dimension over Jacket, mm (in)	28.5 x 17.3 (1.12 x 0.68)

Mechanical Specifications

Weight, kg/m (lb/ft)	0.36 (0.24)
Minimum Bending Radius E Plane, without rebending, mm (in)	125 (4.9)
Minimum Bending Radius H Plane, without rebending, mm (in)	250 (9.8)
Minimum Bending Radius E Plane, with rebending, mm (in)	150 (5.9)
Minimum Bending Radius H Plane, with rebending, mm (in)	400 (15.7)
Maximum Twist, degree/m (degree/ft)	3 (1.0)
Max. Operating Pressure, bar (psi)	0.5 (7.3)
Max. Pulling Length per Hoisting Grip, m (ft)	60 (197)
Standard Hanger Spacing, m (ft)	1.0 (3)
Recommended Installation Temperature Range, °C (°F)	-20 to +60 (-4 to +140)
Recommended operation temperature range, °C (°F)	-40 to +80 (-40 to +176)



Electrical Specifications

Cut-off Frequency, GHz	7.75
Frequency Range, GHz	11.7-13.25
Max. VSWR / Return Loss, dB	1.05/32.26

VSWR values include connectors and are valid for frequency band of connectors.

RWE127 Attenuation, Average Power, Group Velocity

Frequency GHz	Attenuation dB/100 m (ft)	Avg. Pow. kW	Group Vel. %c
11.7	12.41 (3.78)	1.16	74.9
11.8	12.33 (3.76)	1.17	75.4
11.9	12.26 (3.74)	1.18	75.9
12.0	12.18 (3.71)	1.19	76.3
12.1	12.04 (3.67)	1.19	76.8
12.2	11.98 (3.65)	1.20	77.2
12.3	11.91 (3.63)	1.21	77.7
12.4	11.85 (3.61)	1.21	78.1
12.5	11.80 (3.60)	1.22	78.5
12.6	11.74 (3.58)	1.23	78.8
12.7	11.69 (3.56)	1.23	79.2
12.8	11.63 (3.55)	1.24	79.6
12.9	11.58 (3.53)	1.24	79.9
13.0	11.54 (3.52)	1.25	80.3
13.1	11.49 (3.50)	1.26	80.6

Standard Conditions:
For attenuation: VSWR 1.0, ambient temperature 20° C (68° F).
For average power: VSWR 1.0 and 82° C (180°) F inner temperature 40° C (140° F) ambient..

**RWC75-127, FIXED
CONN. FOR RWE127,
WR75
COVER/GROOVE**

FLANGES

Cover Flanges

Are flat faced UG (MIL) and UBR/UAR (IEC) flanges with clearance holes to mate with cover/gasket or choke flanges. When mating two cover flanges together, a special conductive seal is required for pressurization. The mating of two cover flanges is not common.

Cover/Gasket Flanges

Are flat faced with gasket groove PBR/PAR flanges. The cover/gasket flanges contain clearance holes for mating with choke, cover or cover/gasket flanges. A single gasket is required when mating with cover flange. When mating with a cover/gasket or choke flanges, a double gasket is required.

Choke Flanges

UG (MIL) choke flanges and CBR/CAR (IEC) choke flanges contain tapped holes for mating with a cover or cover gasket flange. A single gasket is required when mating a choke flange to a cover flange. When mating a choke flange with a cover/gasket flange, a double is required. Two choke flanges cannot be mated.

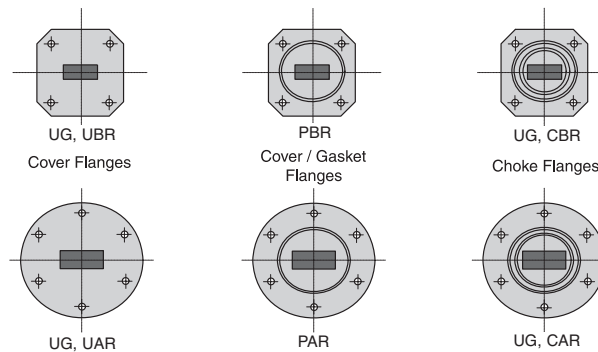

Cover, Cover/Gasket and Choke flanges are square or round depending on waveguide size. MIL and IEC flanges are designed to be interchangeable. All waveguide flanges are supplied with proper gaskets and hardware. Note that the gaskets are required to fill the groove(s) when two flanges are mated. The gaskets required will equal the number of grooves in total mating.

Recmd. Operating Frequency Range, GHz	Flange Shape	W/G EIA Size	U.S. MIL Type Choke Flange	IEC Type Choke Flange	U.S. MIL Type Cover Flange	IEC Type Cover Flange	IEC Type Cov./Gasket Flange	Outside Dimensions In. (mm)
26.50-40.00	square	WR-28	UG-600A/U	N/A	UG-599/U	N/A	N/A	0.75 (19.0)
18.00-26.50	square	WR-42	UG-596A/U	CBR220	UG-595/U	UBR220	PBR220	0.88 (22.4)
12.40-18.00	square	WR-62	UG-541A/U	CBR140	UG-419/U	UBR140	PBR140	1.31 (33.3)
10.00-15.00	square	WR-75	N/A	CBR120	N/A	UBR120	PBR120	1.50 (38.1)
8.200-12.40	square	WR-90	UG-40B/U	CBR100	UG-39/U	UBR100	PBR100	1.63 (41.4)
7.050-10.00	square	WR-112	UG-52B/U	CBR84	UG-51/U	UBR84	PAR84	1.88 (47.8)
5.850-8.200	round	WR-137	UG-343B/U	CAR70	UG-344/U	UAR70	PAR70	3.13 (79.5)

* Radio Waves RS models up to 11 GHz have a standard EIA flange. 13 GHz and above are supplied with a tapped threaded hole pattern that mates with a IEC UBR flange. The flange face includes a gasket groove. Gasket is supplied with the antenna. Blind tapped holes are utilized to minimize required hardware. Please refer to the antenna section of the catalog to determine the proper flange for a particular antenna model.

FLANGES- CONTINUED

CPR (G) Flanges

Are gasket groove flanges, and mate with other CPR(G) flange using the supplied half gasket and U.S. hardware.

PDR Series Flanges

Are gasket groove flanges, and mate with other PDR flanges using the two gaskets and metric hardware. The PDR flanges require different gaskets than CPR because of the deeper gasket grooves.

CPR (F) Flanges

Are flat flanges, and when mated with other CPR(F) flanges, a special conductive seal is required. When mated to a CPR(G) flange, a one-half thickness gasket is required.

UDR Series Flanges

Are flat flanges, and when mated with other UDR flanges, a special conductive seal is required. When mated to a PDR flange, a one-half thickness gasket is required

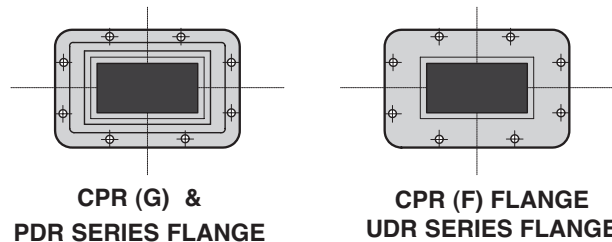

Waveguide Type, EIA	EIA	With Groove MIL Type	IEC	EIA	Without Groove MIL Type	Dimensions inches (mm)
WR75	---	---	PDR120	---	---	1.94 x 1.57 (49.2 x 39.9)
WR90	CPR90G	UG-1360/U	PDR100*	CPR90F	UG-1736/U	2.09 x 1.59 (53.1 x 40.4)
WR112	CPR112G	UG-1358/U	PKD84*	CPR112F	UG-1734/U	2.50 x 1.75 (63.5 x 44.5)
WR137	CPR137G	UG-1356/U	PDR70**	CPR137F	UG-1732/U	2.69 x 1.94 (68.3 x 49.3)

*Mates with equivalent CPR series flange with 4 mm hardware only.

**Mates with equivalent CPR series flange with U.S. #10 hardware only.

FLEX TWIST WAVEGUIDE, FT SERIES

Construction

The basic construction of the guide, irrespective of size or individual specification, consists of an inner core, two connecting flanges soft-soldered into position, and a protective outer jacket.

The Core

The core is manufactured from pre-convoluted brass strip helically wound to extremely close tolerances around a rectangular mandrel. Twistable cores (FT) are silver-clad and are locked by a plated copper sealing wire inserted into their seam during winding. At this stage pressurization is not possible. In order to hold pressure the flexible twistable waveguide must be encased in a rubber jacket.

Neoprene

Shore Hardness: 45° -50°

Operating Temp.: -50°C to +100°C

Silicone

Shore Hardness: 45° -50°

Operating Temp.: -55°C to +135°C



Electrical Specifications for Flex Twist “FT” Waveguide

IEC-R	EIA Size	Matching Rigid W/G Internal Dimensions (in.)	Operation Frequency Band (GHz)	Nominal Test Freq. for Attenuation (GHz)	Maximum IL Attenuation (dB/ft)	Maximum VSWR CR/CPR OR Cover/Cover Flanges		Maximum VSWR CPR/CPR OR Cover/Cover Flanges CW		Power Rating FT CW (kW)
						<36"	>36"	<36"	>36"	
70	137	1.372 x 0.622	5.85 - 8.20	6.45	0.09	1.05	1.09	1.09	1.10	2.00
84	112	1.122 x 0.497	7.05 - 10.00	9.40	0.12	1.07	1.10	1.10	1.13	1.26
100	90	0.900 x 0.400	8.20 - 12.40	9.40	0.15	1.07	1.10	1.10	1.13	0.96
120	75	0.750 x 0.375	10.00 - 15.00	13.70	0.18	1.08	1.10	1.10	1.13	0.75
140	62	0.622 x 0.311	12.40 - 18.00	14.00	0.28	1.10	1.13	1.13	1.16	0.22
220	42	0.420 x 0.170	18.00 - 26.50	22.00	0.70	1.18	1.23	1.20	1.25	0.10
320	28	0.280 x 0.140	26.50 - 40.00	34.00	1.00	1.30 - 36" max.		1.30 - 36" max.		0.10

FLEX TWIST WAVEGUIDE, FT SERIES

Mechanical Specifications for Flex Twist “FT” Waveguide

Dash No	IEC-IR ()	EIA Size WR	TWIST FT Bending Rating				TWIST ONLY FT Twisting Rating		Max. Operating Pressure FT psig
			STATIC		REPEATED		Static Tolerance	Repeated Twist	
			E-plane Rad (in.)	H-plane Rad (in.)	E-plane Rad (in.)	H-plane Rad (in.)			
01	32	284	7.0	14.0	28.0	56.0	32 ±deg/ft	8 ±deg/ft	20
02	40	229	6.5	13.0	26.0	52.0	40 ±deg/ft	10 ±deg/ft	30
03	48	187	6.5	13.0	26.0	52.0	48 ± deg/ft	12 ±deg/ft	30
04	58	159	5.0	10.0	20.0	40.0	56 ±deg/ft	14 ±deg/ft	30
05	70	137	4.0	8.0	16.0	32.0	64 ±deg/ft	16 ±deg/ft	30
06	84	112	3.0	6.0	12.0	24.0	80 ±deg/ft	20 ±deg/ft	35
07	100	90	2.5	5.0	10.0	20.0	96 ±deg/ft	24 ±deg/ft	45
08	120	75	2.5	4.5	10.0	20.0	112 ±deg/ft	28 ±deg/ft	45
09	140	62	2.0	4.0	8.0	16.0	136 ±deg/ft	34 ±deg/ft	45
10	180	51	2.0	4.0	8.0	16.0	136 ±deg/ft	34 ±deg/ft	45
11	220	42	1.5	3.0	6.0	12.0	155 ±deg/ft	45 ±deg/ft	45
13	320	28							

FLEX TWIST WAVEGUIDE ORDERING GUIDE

Flex Twist Ordering Guide - FT90FC02C

Product Identifier	Waveguide Size	Length, F= Feet C=Centimeters	Flange 1 Code	Length	Flange 2 Code
FT	90	F	C	02	C

Description: Flex Twist, WR90 (8.2 - 12.4 GHz), Length in Feet, Flange 1 is a CPR90G, Length is 2 feet, Flange 2 is a CPR90G.

Table 1: Flange Codes, Description and Availability

Code	Flange Type*	Description	Available for Waveguide Size
A	UG-Choke	Tapped Holes, Gasket Groove, Choke Groove, Square Flange	28, 42, 62, 75, 90 & 112
A	UG-Choke	Tapped Holes, Gasket Groove, Choke Groove, Circular Flange	137
B	UG-Cover	Through Holes, No Gasket Groove or Choke Groove, Square Flange	28, 42, 62, 75, 90 & 112
B	UG-Cover	Through Holes, No Gasket Groove or Choke Groove, Circular Flange	137
C	CPR ()G	Through Holes, Gasket Groove, Rectangular Flange	90, 112 & 137
D	CPR ()F	Through Holes, No Gasket Groove, Rectangular Flange	90, 112 & 137
E	CMR	Alternate Tapped Holes, No Gasket Groove, Rectangular Flange	90, 112 & 137
F	CMR Through	All Through Holes, No Gasket Groove, Rectangular Flange	137
G	CMR Through	All Tapped Holes, No Gasket Groove, Rectangular Flange	137
H	PDR	Through Holes, Gasket Groove, Rectangular Flange	62, 75, 90, 112 & 137
I	UDR	Through Holes, No Gasket Groove, Rectangular Flange	62, 75, 90, 112 & 137
J	PBR	Through Holes, Gasket Groove, No Choke, Square Flange	28, 42, 62, 75, 90 & 112
K	UBR	Through Holes, No Gasket Groove, No Choke, Square Flange	28, 42, 62, 75 & 112
L	PAR	Through Holes, Gasket Groove, No Choke, Circular Flange	137
M	UG-Cover/Gasket	Through Holes, Gasket Groove, No Choke, Square Flange	28, 42, 62, 75, 90 & 112
N	UG-Cover/ Gasket	Through Holes, Gasket Groove, No Choke, Circular Flange	137

* Other flange options are available on request. Please contact a Radio Waves authorized representative.

Table 2: Size and Frequency Codes

EIA	IEC	Waveguide Size Code	Frequency, GHz
WR28	R320	28	26.50 - 40.00
WR42	R220	42	17.70 - 26.50
WR62	R140	62	12.40 - 18.40
WR75	R120	75	10.00 - 15.00
WR90	R100	90	8.200 - 12.40
WR112	R84	112	7.050 - 10.00
WR137	R70	137	5.850 - 8.200

Table 3: Flex Twist Models

WG Size	Model #	Flange 1	Flange 2	Length
WR137	FT137FC02C	CPR137G	CPR137G	2
WR137	FT137FC03C	CPR137G	CPR137G	3
WR137	FT137FA02C	UG343	CPR137G	2
WR137	FT137FA03C	UG343	CPR137G	3
WR112	FT112FC02C	CPR112G	CPR112G	2
WR112	FT112FC03C	CPR112G	CPR112G	3
WR112	FT112FA02B	UG52B	UG51	2
WR112	FT112FA03B	UG52B	UG51	3
WR112	FT112FA02A	UG52B	UG52B	2
WR112	FT112FA03A	UG52B	UG52B	3
WR90	FT90FA02B	UG40B	UG39B	2
WR90	FT90FA03B	UG40B	UG39B	3
WR90	FT90FC02C	CPR90G	CPR90G	2
WR90	FT90FC03C	CPR90G	CPR90G	3
WR75	FT75FA02B	WR75CHOKE	WR75COVER	2
WR75	FT75FA03B	WR75CHOKE	WR75COVER	3
WR75	FT75FJ02K	PBR120	UBR120	2
WR75	FT75FJ03K	PBR120	UBR120	3
WR62	FT62FA02B	WR62CHOKE	WR62COVER	2
WR62	FT62FA03B	WR62CHOKE	WR62COVER	3
WR62	FT62FJ02K	PBR140	UBR140	2
WR62	FT62FJ03K	PBR140	UBR140	3
WR42	FT42FA02B	UG596	UG595	2
WR42	FT42FA03B	UG596	UG595	3
WR42	FT42FJ02K	PBR220	UBR220	2
WR42	FT42FJ03K	PBR220	UBR220	3
WR42	FT42FB02M	UG cover, UG595	Cover w/O-ring	2
WR42	FT42FB03M	UG cover, UG595	Cover w/O-ring	3

LMR[®] CABLE

Introduction:

Radio Waves offers LMR[®] cable, which is a high performance, flexible, low loss 50-Ohm cable for applications such as short antenna feeder runs, jumper assemblies in wireless communications systems, and as IF cable runs in split radio design applications. LMR[®] cable designs feature a closed cell polyethylene foam dielectric for low loss characteristics. Aluminum tape is employed for a flexible shield. A tinned copper outer braid provides a means for grounding and connector retention, and a heavy-duty polyethylene outer jacket gives the cable UV and weather protection, as well as ensuring a long lasting reliable product.

Selection:

LMR[®] cable is available in a variety of diameters. The cable can be ordered in the desired length as an assembly, or purchased as separate cable and connectors, to be cut and connectorized in the field.

LMR[®] cable is specified for use at frequencies up to 6 GHz. Depending on the model, some LMR cables have cut-off frequencies up to 16 GHz. Please consult the factory for applications above 6 GHz.

Features:

Flexible: With a bend radius of 1-inch for LMR-400, 1.5-inches for LMR-600, 3-inches for LMR-900, and 6.5-inches for LMR-1200, LMR[®] cable can be easily routed into and through tight spaces without kinking. The bonded tape outer conductor provides superior flexibility and ease of bending compared to competitive cables.

Low Loss: LMR-400, and LMR-600 cable have the lowest loss of any “superflex” type cable on the market. The use of high velocity gas-injected closed cell foam dielectric and the bonded aluminum tape outer-conductor in the design of the LMR[®] cable ensure the low loss performance. LMR-900 and LMR-1200 cable has loss characteristics approaching that of 7/8-inch corrugated copper cable at a fraction of the cost.

Weatherproof: The UV protected black polyethylene jacket makes the cable rugged and resistant to the full range of outdoor environments.

RF Shielding: The bonded aluminum tape outer conductor is overlapped to provide 100% coverage, resulting in >90 dB RF shielding, and excellent interference immunity.

Phase Stability: The intimately bonded structure and closed foam dielectric of the LMR[®] cable provides excellent phase stability over temperature and with bending. The high velocity dielectric results in superior phase stability as compared with solid and air-spaced dielectric cables.



Order your jumpers from Radio Waves!

LMR-400 CABLE

Construction Specifications

Part Designation	Material	Inches	MM
Inner conductor	Solid BCCAI	0.108	2.74
Dielectric	Foam polyethylene	0.285	7.24
Outer conductor	Aluminum Tape	0.291	7.39
Overall braid	Tinned Copper	0.320	8.13
Standard Jacket	Black polyethylene	0.405	10.29

Environmental Specifications

Installation temperature range	-40/+185°F	-40/+85°C
Storage temperature range	-94/+185°F	-70/+85°C
Operating temperature range	-40/+185°F	-40/+85°C

Electrical Specifications

Consult factory for applications over 6 GHz

Cutoff frequency	16.2 GHz	
Velocity of propagation	85%	
Voltage withstand	2,500 VDC	
Peak Power	16 kW	
DC resistance		
Inner conductor, ohms	1.39/1,000'	4.56/km
Outer conductor, ohms	1.65/1000'	5.41/km
Jacket spark	8,000 VRMS	
Impedance	50 ohms	
Capacitance	23.9 pF/ft	78.40 pF/m
Inductance	0.060 uH/ft	0.20 uH/m
Shielding effectiveness	>90 dB	
Phase stability	<10 ppm/°C	

Accessories

Tool Type	Part Number	Description
Crimp Tool	HX-4	Crimp Handle
Crimp Dies	Y1719	.429" Hex Dies
Crimp Tool	CT-400/300	Crimp tool for LMR 400
Crimp Rings	CR-400	Crimp rings for TC/EZ-400
Strip Tool	ST-400EZ	For Crimp connectors

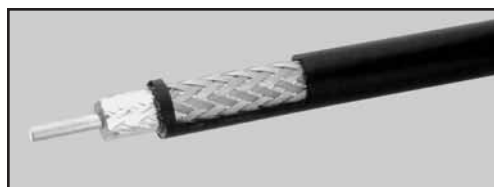

Connectors

Frequency	Attenuation dB/100 ft	Attenuation dB/100m	Avg. Power kW	Interface	Description	Part Number	Outer Contact	Finish* Body/Pin
30 MHz	0.7	2.2	3.3	NMale	Straight Plug	TC-400-NM	Crimp	N/G
50 MHz	0.9	2.9	2.6	NMale	Straight Plug	EZ-400-NMH	Crimp	S/G
150 MHz	1.5	5.0	1.5	NFemale	Straight Jack	EZ-400-NF	Crimp	N/G
220 MHz	1.9	6.1	1.2	TNCMale	Straight Plug	TC-400-TM	Crimp	N/S
450 MHz	2.7	8.9	0.83	TNCMale	Straight Plug	EZ-400-TM	Crimp	N/S
900 MHz	3.9	12.8	0.58	SMAMale	Straight Plug	TC-400-SM	Crimp	N/G
1500 MHz	5.1	16.8	0.44					
1800 MHz	5.7	18.6	0.40					
2000 MHz	6.0	19.6	0.37					
2500 MHz	6.8	22.2	0.33					
5800 MHz	10.8	35.5	0.21					

*Finish metals: N=Nickel, S=Silver, G=Gold, SS=Stainless Steel, A=Alballoy

LMR-600 CABLE

Construction Specifications

Part Designation	Material	Inches	MM
Inner conductor	Solid BCCAI	0.176	4.47
Dielectric	Foam polyethylene	0.455	11.56
Outer conductor	Aluminum Tape	0.461	11.71
Overall braid	Tinned Copper	0.490	12.45
Standard Jacket	Black polyethylene	0.590	14.99

Environmental Specifications

Installation temperature range	-40/+185°F	-40/+85°C
Storage temperature range	-94/+185°F	-70/+85°C
Operating temperature range	-40/+185°F	-40/+85°C

Electrical Specifications

Consult factory for applications over 6 GHz

Cutoff frequency	10.3 GHz	
Velocity of propagation	87%	
Voltage withstand	4,000 VDC	
Peak Power	40 kW	
DC resistance		
Inner conductor, ohms	0.53/1,000'	1.74/km
Outer conductor, ohms	1.2/1000'	3.94/km
Jacket spark	8,000 VRMS	
Impedance	50 ohms	
Capacitance	23.4 pF/ft	76.8 pF/m
Inductance	0.058 uH/ft	0.19 uH/m
Shielding effectiveness	>90 dB	
Phase stability	<10 ppm/°C	

Accessories

Tool Type	Part Number	Description
Crimp Dies	Y1720	.610" Hex Dies
Crimp Rings	CR-600	Crimp rings for TC/EZ-600
Strip Tool	ST-600C	For Clamp connectors
Strip Tool	ST-600EZ	For Crimp connectors
Deburr Tool	DBT-01	For 'EZ' connectors

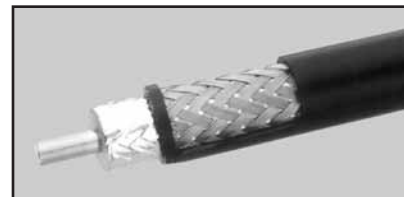

Connectors

Frequency	Attenuation dB/100 ft	Attenuation dB/100m	Avg. Power kW	Interface	Description	Part Number	Outer Contact	Finish* Body/Pin
30 MHz	0.42	1.4	5.5	NMale	Straight Plug	EZ-600-NMH	Crimp	S/G
50 MHz	0.55	1.8	4.2	NMale	Straight Plug	EZ-600-NMC	Clamp	S/G
150 MHz	1.0	3.2	2.4	NFemale	Straight Jack	EZ-600-NF	Crimp	N/G
220 MHz	1.2	3.9	2.0					
450 MHz	1.7	5.6	1.35					
900 MHz	2.5	8.2	0.93					
1500 MHz	3.3	10.9	0.70					
1800 MHz	3.7	12.1	0.63					
2000 MHz	3.9	12.8	0.59					
2500 MHz	4.4	14.5	0.52					
5800 MHz	7.3	23.8	0.32					

*Finish metals: N=Nickel, S=Silver, G=Gold, SS=Stainless Steel, A=Alloy

LMR-900 CABLE

Construction Specifications

Part Designation	Material	Inches	MM
Inner conductor	BC Tube	0.262	6.65
Dielectric	Foam polyethylene	0.680	17.27
Outer conductor	Aluminum Tape	0.686	17.42
Overall braid	Tinned Copper	0.732	18.59
Standard Jacket	Black polyethylene	0.870	22.10

Environmental Specifications

Installation temperature range	-40/+185°F	-40/+85°C
Storage temperature range	-94/+185°F	-70/+85°C
Operating temperature range	-40/+185°F	-40/+85°C

Electrical Specifications

Consult factory for applications over 6 GHz

Cutoff frequency	6.9 GHz	
Velocity of propagation	87%	
Voltage withstand	5,000 VDC	
Peak Power	62 kW	
DC resistance		
Inner conductor, ohms	0.54/1,000'	1.77/km
Outer conductor, ohms	0.55/1000'	1.80/km
Jacket spark	8,000 VRMS	
Impedance	50 ohms	
Capacitance	23.4 pF/ft	76.8 pF/m
Inductance	0.058 uH/ft	0.19 uH/m
Shielding effectiveness	>90 dB	
Phase stability	<10 ppm/°C	

Accessories

Tool Type	Part Number	Description
Strip Tool	ST-900/1200C	For Clamp connectors

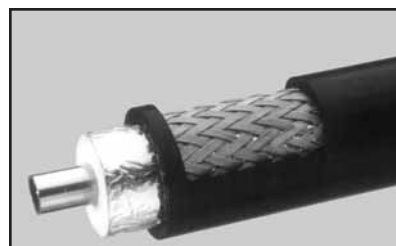

Connectors

Frequency	Attenuation dB/100 ft	Attenuation dB/100m	Avg. Power kW	Interface	Description	Part Number	Outer Contact	Finish* Body/Pin
30 MHz	0.29	0.9	8.9	NMale	Straight Plug	EZ-900-NMC	Clamp	S/S
50 MHz	0.37	1.2	6.9	NFemale	Straight Jack	EZ-400-NFC	Clamp	S/S
150 MHz	0.66	2.2	3.9					
220 MHz	0.80	2.6	3.2					
450 MHz	1.17	3.8	2.2					
900 MHz	1.70	5.6	1.5					
1500 MHz	2.24	7.4	1.1					
1800 MHz	2.48	8.2	1.0					
2000 MHz	2.63	8.6	1.0					
2500 MHz	2.98	9.8	0.9					
5800 MHz	4.90	16.0	0.52					

*Finish metals: N=Nickel, S=Silver, G=Gold, SS=Stainless Steel, A=Alballoy

LMR-1200 CABLE

Construction Specifications

Part Designation	Material	Inches	MM
Inner conductor	BC Tube	0.349	8.86
Dielectric	Foam polyethylene	0.920	23.37
Outer conductor	Aluminum Tape	0.926	23.52
Overall braid	Tinned Copper	0.972	24.69
Standard Jacket	Black polyethylene	1.200	30.48

Environmental Specifications

Installation temperature range	-40/+185°F	-40/+85°C
Storage temperature range	-94/+185°F	-70/+85°C
Operating temperature range	-40/+185°F	-40/+85°C

Electrical Specifications

Consult factory for applications over 6 GHz

Cutoff frequency	5.2 GHz	
Velocity of propagation	88%	
Voltage withstand	6,000 VDC	
Peak Power	90 kW	
DC resistance		
Inner conductor, ohms	0.32/1,000'	1.05/km
Outer conductor, ohms	0.37/1000'	1.21/km
Jacket spark	8,000 VRMS	
Impedance	50 ohms	
Capacitance	23.1 pF/ft	75.8 pF/m
Inductance	0.056 uH/ft	0.18 uH/m
Shielding effectiveness	>90 dB	
Phase stability	<10 ppm/°C	

Accessories

Tool Type	Part Number	Description
Strip Tool	ST-900/1200C	For Clamp connectors



Connectors

Frequency	Attenuation dB/100 ft	Attenuation dB/100m	Avg. Power kW	Interface	Description	Part Number	Outer Contact	Finish* Body/Pin
30 MHz	0.21	0.7	12.6	NMale	Straight Plug	EZ-1200-NMC	Clamp	S/S
50 MHz	0.27	0.9	9.7	NFemale	Straight Jack	EZ-1200-NFC	Clamp	S/S
150 MHz	0.48	1.6	5.5					
220 MHz	0.59	1.9	4.5					
450 MHz	0.86	2.8	3.1					
900 MHz	1.3	4.2	2.1					
1500 MHz	1.7	5.5	1.6					
1800 MHz	1.9	6.1	1.4					
2000 MHz	2.0	6.5	1.3					
2500 MHz	2.3	7.4	1.2					

*Finish metals: N=Nickel, S=Silver, G=Gold, SS=Stainless Steel, A=Alballoy

ACCESSORIES

Angle Adaptor Kit:

Angle Adaptors are used to securely fasten coaxial cable hangers on solid angle tower members. Angle Adaptors mount to angle support members, which reduces time by eliminating field modifications. The 3/8" tapped holes enable the adaptor to accommodate any coaxial cable hanger that utilizes standard 3/8" hardware. The adaptors directly mount to angle members up to 7/8" (22mm) thick and are fastened in place with an included square-head bolt and toothed jaws, providing a secure and dependable mounting solution. The heavy-duty design is constructed of stainless steel to ensure long field life. The Angle Adaptor kits are comprised of 10 adaptors, 10 hanger mounting slotted screws, 3/8 x 3/8 long and 10 slotted flat washers.

Model # AA2S



Universal Grounding Kit:

The universal grounding kit features an innovative "one size fits all" design. The kit accommodates any coaxial cable from .5" to 3" (12.7mm to 76.2mm) in diameter as well as elliptical waveguide ranging from 37 to 191. The flat copper ground strap is pre-scored and marked for each diameter, to ease field installation. Each kit consists of a 5-foot (1.05m), 6-gauge (13.3mm²), 7-strand copper ground lead with attached two-hole lug. Electrical and weatherproofing tape are also included with each kit.

Model # RGNG



Standard Grounding Kits:

The Standard Ground kits allow for ease of installation with a pre-formed copper strap that eliminates the need for a coiling tool and prevents overtightening. The kit includes a 5-foot (1.05m), 6-gauge (13.3mm²), 7-strand copper ground lead, which can be cut to exact length for a clean and effective grounding installation. Included in each kit are a two-hole 3/8" (9.5mm) universal lug and all hardware necessary for proper installation. Electrical and weatherproofing tape are also included with each kit.

Coaxial Cable

Model #	Description
GK-200	Standard Grounding Kit LMR-200 cable
GK-240	Standard Grounding Kit LMR-240 cable
GK-400	Standard Grounding Kit LMR-400 cable
GK-600	Standard Grounding Kit LMR-600 cable
GK-900	Standard Grounding Kit LMR-900 cable
GK-1200	Standard Grounding Kit LMR-1200 cable

Elliptical W/G

Model #	Description
GK-RWE78	Standard Grounding Kit RWE78 W/G
GK-RWE105	Standard Grounding Kit RWE105 W/G
GK-RWE130	Standard Grounding Kit RWE130 W/G
GK-RWE150	Standard Grounding Kit RWE150 W/G

ACCESSORIES

Hoisting Grip:

Hoisting Grips provide an effective method to lifting coaxial cable and elliptical waveguide into position, and offers additional support once coax cable or elliptical waveguide is installed. Grips are spilt type and may be affixed to cable or waveguide with metal lace. The lace design allows installation of the grip even after the waveguide or cable has been terminated. The recommended interval spacing between grips is 200 ft (61m).



Coaxial Cable

Model #	Description
HG-600	Hoisting Grip LMR-600 coax cable
HG-900	Hoisting Grip LMR-900 coax cable
HG-1200	Hoisting Grip LMR-1200 coax cable

Elliptical W/G

Model #	Description
HG-RWE78	Hoisting Grip RWE78
HG-RWE105	Hoisting Grip RWE105
HG-RWE130	Hoisting Grip RWE130
HG-RWE150	Hoisting Grip RWE150

ACCESSORIES

RWL4 AUTOMATIC DEHYDRATOR SERIES & AIR DISTRIBUTION MANIFOLD KIT

The dehydrator has been designed for continuous operation and automatic duty. It supplies dry air up to 300 nl/h, at a dew point better than -40 degrees celcius. The output pressure is selectable within the range 0.1 kPa - 6.0 kPa with a 0.1 kPa step.

Dry air is supplied by 2 standard independent air outlets with hose-tail on the top panel of the equipment. Each outlet is supplied with shutoff valve and each couple is supplied on demand with flowmeter check air output.

Air drying is performed by means of two drying towers (operating on alternate cycle) that contain granular substances: the air flows inside the drying tower and lost most of molecules of water for chemical absorption. While one tower dries the other one is regenerated by heating and backwashing with a reverse dry air flow. An electronic microprocessor board controls drying cycles and adjusts their duration according to air output.

Air is compressed by two disphragm pumps. A fundamental characteristic of the RWL4 dehydrator is the continuous tracking of the output pressure. the PWM (Pulse Width Modulation) technique has been used to control the speed of the two pumps (one for each drying tower), so we can reduce to a minimum pump duty, power consumption and acoustic noise, and increase reliability (with pumps operating pressure equal to output pressure).

Pump speed control eliminates mechanical pressure regulators that introduce undesirable pressure losses and a worst response to flow rate requirements.

The equipment is designed for 19" standard rack mounting, with 7 U modular height.

The dehydrator does not require pre-settings nor warm-up time to start-up. It does not require preventative maintenance.

All of the components employed are not radio-active or chemically hazardous.

The following devices are located on the front panel:

- control switch fuse holders
- liquid crystal display (2 x 16 characters) where output air pressure, hour-meter, any alarm message and function setting menus are displayed
- two functions keys to display and modify equipment settings
- LED's "POWER ON" (green) and "WARNING" (red)
- shutoff valves air outlets
- shutoff valves drive panel

On the top panel are located:

- power supply connector
- remote alarm connector
- outlets with hose-tail according to equipment configuration.

A manual is included with the dehydrator that provides all the details for field installation.

Model RWL4-EXP4 RWL4-PORT EXPANSION KIT

The automatic dehydrator RWL4 normally comes with 4 ports to connect 4 waveguide transmission lines. The kit **RWL4-EXP4** allows 4 more ports by a very simple step in order to service additional waveguide lines. A manual is included with the kit that provides all the details for field installation.

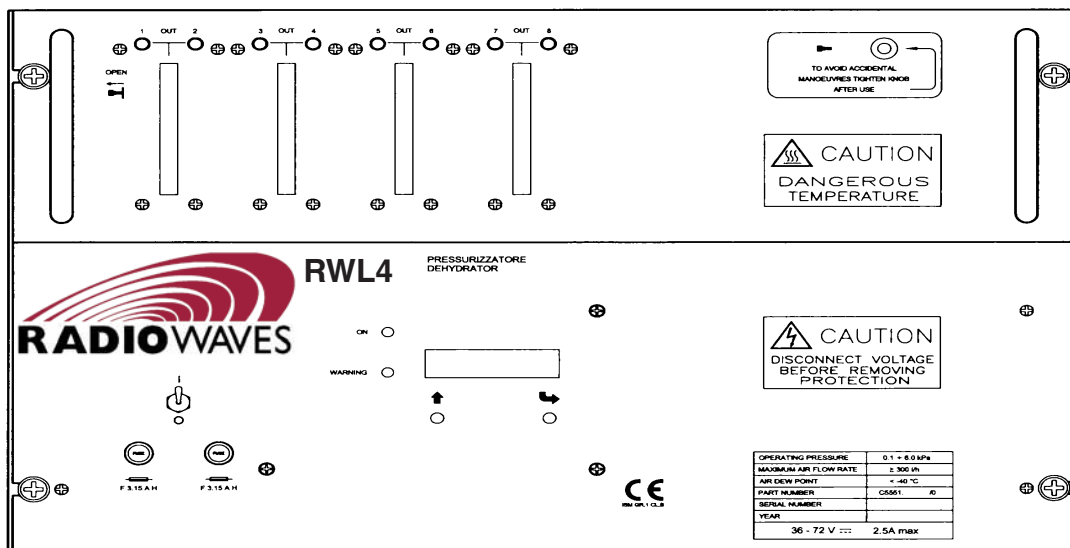

ACCESSORIES

RWL4 AUTOMATIC DEHYDRATOR SERIES

Output pressure	programmable from 0.1 kPa to 6.0 kPa, factory set at 2.0 kPa
Maximum flow rate	300 nl/h
Safety valve	built in, factory set at 6.0 kPa +/- 15%
output air dew point	better than -40 deg. C, @ 20 deg. C ambient temperature, 80% relative humidity
Desiccant regeneration	automatic by heating
Regeneration phase duration	75 min
Regeneration phase interval	from 4h 30 min to 14h according to flow rate
Alarms	power failure, high humidity, low pressure, high pressure (optional) and high flow (optional)
Low pressure alarm	programmable from 0kPa up to output pressure set point, factory set at 1.5 kPa
High humidity alarm	set at 10% of relative humidity +/-2%
High pressure alarm (optional)	programmable from "operating pressure + 0,2 kPa" up to 6.3 kPa, factory set at 4.5 kPa
Measures	air pressure, hour meter
Pressure meter	full scale 6.3 kPa, resolution 0.1 kPa, accuracy +/-5% of full scale +/-1 digit
Led indications	power on, warning
Acoustic noise	<- 50 dBa at 1 m far and 1,5 m high
Enclosure degree of protection	IP20 according to IEC529
Operating Temperature	-10 deg. C / + 50 deg. C
Storage Temperature	-30 deg. C / +60 deg. C
AC model power Option 1	115 Vac +/- 10% 50/60 Hz
AC model power Option 2	230 Vac +/- 10% 50/60 Hz
	< 10 W (at steady state without system leakage)
	< 110 W (during regeneration phase)
Dimensions	- wall mounting: L= 486; H=311; D=135mm - rack19" mounting: L=482; H=310 (7U); D=110mm
European Community Directives	Low Voltage Directive: 73/23/CCE (as modified directive 93/68/CCE); Electromagnetic Compatibility Directive: 89/336/CCE (as modified by directives 92/31/CCE and 93/68/CCE)
Safety Standards	EN 60950 Safety information technology equipment, including electrical business equipment
Electromagnetic	EN 55022 class A and B
Compatibility Standard	EN 50082-1
Quality Assurance Standard	ISO 9001
Weight (with desiccant)	14 kg (25.77 lb) wall mounting
Air Outlet Configuration	type A N.1 couple, each with shutoff valve, with no flowmeter (couples: min 1 max 6)
Hose-tail fitting	- standard 9,5 mm external diameter - others on request

STANDARD DRUM SIZES. LENGTH CAPACITY CHART FOR LMR[®] CABLE

			Flange in. (mm)	10 (254)	12 (305)	16 (406)	16 (406)	15 (381)	17.75 (451)	24 (610)	24 (610)	30 (762)	30 (762)	36 (914)	36 (914)		
			Width in. (mm)	9 (229)	9 (229)	9 (229)	9 (229)	9.75 (248)	15 (381)	11.5 (292)	14 (356)	14 (356)	14 (356)	14 (356)	14 (356)		
			FxW in. (mm)	10x9 (254x229)	12x9 (305x229)	16x9 (406x229)	16x9 (406x229)	15x9.75 (381x248)	17.75x15 (451x381)	24x11.5 (610x292)	24x14 (610x356)	30x14 (762x356)	30x14 (914x356)	36x14 (914x356)	36x14 (914x356)		
Cable			Drum Height Only lbs. (kg)	2.5 (1.1)	3 (1.4)	3 (1.4)	4 (1.8)	7 (3.2)	11 (5.0)	14 (6.4)	15 (6.8)	19 (8.6)	29 (13.2)	47 (21.3)	38 (17.2)		
Type	Weight lb/ft (kg/m)	Diameter in. (m)	Volume Cu. ft (Cu. meters)	0.57 (0.016)	0.83 (0.023)	1.47 (0.042)	1.47 (0.042)	1.40 (0.040)	3.01 (0.085)	4.22 (0.119)	5.13 (0.145)	8.02 (0.227)	8.02 (0.227)	11.6 (0.327)	11.6 (0.327)		
LMR-200	.022 (.033)	.195 (4.95)	Maximum Cable Length Capacity per Reel ft (m)	676 (206)	1197 (365)	1816 (553)	2822 (860)	2634 (803)	4909 (1496)								
LMR-240	.034 (.051)	.240 (6.10)		423 (129)	851 (259)	1125 (343)	1799 (548)	1695 (517)	3109 (948)	4672 (1424)							
LMR-400	.068 (.101)	.405 (10.29)			296 (90)	406 (124)	619 (189)	542 (165)	1110 (338)	1504 (459)	2166 (660)	2095 (639)	3403 (1037)	3834 (1169)			
LMR-600	.131 (.195)	.590 (14.99)							504 (154)	723 (220)	1024 (312)	904 (276)	1590 (485)	1743 (531)	2443 (745)		
LMR-900	.266 (.396)	.870 (22.10)											717 (219)	789 (240)	1059 (323)		
LMR-1200	.448 (.667)	1.200 (30.48)													616 (188)		

			Flange in. (mm)	36 (914)	42 (1067)	54 (1372)	62 (1575)	72 (1829)
			Width in. (mm)	26 (660)	26 (660)	26 (660)	26 (660)	36 (914)
			FxW in. (mm)	36x26 (914x660)	42x26 (1067x660)	54x26 (1372x660)	62x26 (1575x660)	72x36 (1829x914)
Cable			Drum Height Only lbs. (kg)	77 (34.9)	105 (47.6)	154 (69.9)	193 (87.5)	390 (176.9)
Type	Weight lb/ft (kg/m)	Diameter in. (m)	Volume Cu. ft (Cu. meters)	21.5 (.607)	29.2 (0.827)	48.3 (1.367)	63.6 (1.802)	118.8 (3.364)
LMR-200	.022 (.033)	.195 (4.95)	Maximum Cable Length Capacity per Reel ft (m)					
LMR-240	.034 (.051)	.240 (6.10)						
LMR-400	.068 (.101)	.405 (10.29)						
LMR-600	.131 (.195)	.590 (14.99)		3249 (990)	2549 (777)			
LMR-900	.266 (.396)	.870 (22.10)		1473 (449)	977 (298)	3511 (1070)	5070 (1545)	
LMR-1200	.448 (.667)	1.200 (30.48)		796 (243)	525 (160)	1639 (499)	2744 (837)	4061 (1238)

Note: Cable length capacity per reel and reel sizes are a general guideline only, and do not necessarily represent how specific lengths may be shipped. Capacity chart is applicable to all LMR types, including -DB, -FR, PVC, -LLPL, _UltraFlex.

SHIPPING INFORMATION

All Radio Waves antennas are packed in either boxes or wooden crates, depending on size, and shipped standard freight or by customer requested freight.

Antennas up to 2-ft (0.6m) are shippable by UPS. Antennas over 2-ft (0.6m) must ship via a standard freight carrier.

Radio Waves can bulk crate up to four SP4 or SP6 antenna's and we can bulk crate up to three SP8 antenna's.

Shipping is available either on the customer's own shipping account or via pre-pay and add.

Cardboard boxes and crates are marked with Radio Waves' Sales order number and are shipped with a Radio Waves' packing slip noting contents of shipment, ship-to address, as well as Radio Waves' sales order number and customer purchase order number. Smaller parts for an antenna shipped in a wooden crate are kept in a cardboard box at the bottom of the crate.

Shipping is available from either our Billerica, Massachusetts, USA or London, UK facilities.



Packaging for the (l-r) SP2 with radome, SP2 without radome, and the SP1



Wooden Crate Packing: SP3, SP4 and SP6 models. SP3, SP4 radomes are attached prior to shipping. The SP6 radome is shipped unattached in order to minimize the diameter of crate.



HP8, SP8 with & without Radome

SHIPPING INFORMATION

G SERIES, GRID ANTENNAS

Model Number	Diameter ft., (cm)	Package Type	Net Weight lbs. (kg)	Gross Weight lbs. (kg)	Dimensions, L x W x H Inches, (cm)	Cubic ft. (m)
G2	2 (0.6)	Cardboard	25 (11.3)	26 (11.8)	29 x 29 x 7 (73 x 73 x 17)	16.2 (0.5)
G3	3 (0.9)	Cardboard	25 (11.3)	100 (45.3)	40 x 17 x 44 (101 x 43 x 111)	16.2 (0.5)
G4	4 (1.2)	Wood Crate	35 (15.8)	120 (54.4)	53 x 16 x 58 (134 x 40 x 147)	27.1 (0.8)
G6	6 (1.8)	Wood Crate	80 (36.0)	210 (95.2)	74 x 18 x 81 (198 x 45 x 205)	59.4 (1.7)

SP SERIES, STANDARD PARABOLIC ANTENNAS

SP1	1 (0.3)	Cardboard	15 (6.8)	18 (8.1)	16 x 16 x 10 (41 x 41 x 23)	1.3 (0.1)
SP2	2 (0.6)	Cardboard	22 (9.9)	25 (11.3)	28 x 7 x 27 (71 x 17 x 68)	2.3 (0.1)
W/RD2		Cardboard	26 (11.7)	31 (14.0)	28 x 28 x 15 (71 x 71 x 38)	8.1 (0.2)
RD2	2 (0.6)	Cardboard	7 (3.2)	9 (4.0)	28 x 7 x 27 (71 x 17 x 68)	16.3 (0.5)
SP3	3 (0.9)	Wood Crate	35 (15.8)	95 (43.0)	40 x 17 x 44 (101 x 43.2 x 112)	17.3 (0.5)
SP3 w/RD3		Wood Crate	43 (19.4)	105 (47.6)	40 x 30 x 54 (101 x 43.2 x 137.2)	21.25 (0.6)
RD3	3 (0.9)	Cardboard	9 (4.0)	11 (5.0)	37 x 37 x 13 (93 x 93 x 33)	16.3 (0.5)
SP4	4 (1.2)	Wood Crate	60 (27.0)	165 (74.8)	59 x 19 x 60 (149 x 48 x 152)	36.9 (1.0)
SP4 w/RD4		Wood Crate	80 (36.0)	185 (83.9)	58 x 35 x 60 (147 x 88 x 152)	57.4 (1.6)
RD4	4 (1.2)	Wood Crate	45 (29.4)	65 (29.4)	52 x 18 x 53 (132 x 45 x 135)	16.3 (0.5)
SP6	6 (1.8)	Wood Crate	95 (42.8)	230 (104.3)	77 x 20 x 80 (195 x 50 x 203)	57.0 (1.6)
SP6 w/RD6		Wood Crate	125 (56.3)	250 (112.5)	77 x 18 x 80 (196 x 46 x 203)	57.0 (1.6)
SP8	8 (2.4)	Wood Crate	165 (74.3)	900 (408.0)	102 x 60 x 91 (259 x 152 x 231)	322.3 (9.1)
DP6 w/RD6	6 (1.8)	Wood Crate	94 (42.6)	214 (96.9)	77 x 20 x 80 (195 x 50 x 203)	57.0 (1.6)
SP8 w/RD8	8 (2.4)	Wood Crate	350 (157.5)	1100 (498.0)	104 x 80 x 94 (264 x 203 x 238)	452.6 (12.8)
RD8	8 (2.4)	Wood Crate	165 (74.3)	900 (408.0)	102 x 60 x 91 (259 x 152 x 231)	322.3 (9.1)

HP SERIES, HIGH PERFORMANCE ANTENNAS

HPCPE	1 (0.3)	Cardboard	15 (6.8)	19 (8.6)	25 x 16 x 13 (63 x 40 x 33)	3.7 (0.1)
HPLP1	1 (0.3)	Cardboard	17 (7.7)	24 (10.8)	18 x 18 x 19 (45 x 45 x 48)	3.7 (0.1)
HP2	2 (0.6)	Cardboard	27 (12.3)	48 (21.7)	29 x 29 x 27 (71 x 71 x 61)	10.2 (0.3)
HP3	3 (0.9)	Wood Crate	50 (22.5)	105 (36.0)	47 x 27 x 47 (119 x 69 x 119)	28.7 (0.8)
HP4	4 (1.2)	Wood Crate	85 (38.3)	175 (92.3)	59 x 28 x 60 (150 x 71 x 152)	57.4 (1.6)
HP6	6 (1.8)	Wood Crate	251 (113.0)	405 (182.3)	77 x 34 x 80 (196 x 86 x 203)	103.4 (2.9)
HP8	8 (2.4)	Wood Crate	424 (194.5)	1150 (517.5)	98 x 80 x 86 (249 x 203 x 218)	

SEC SERIES, SECTOR ANTENNAS

SEC-5V-120	----	Cardboard	7 (3.2)	8 (3.6)	12 x 27 x 8 (30 x 68 x 20)	1.2 (.033)
Single Pol	----	Cardboard	11 (5.0)	12 (5.4)	12 x 6 x 27 (31 x 20 x 69)	1.2 (.033)
Dual band	----	Cardboard	15 (6.8)	16 (7.2)	13 x 6 x 44 (33 x 15 x 112)	1.9 (.053)
Dual Po 1	----	Cardboard	15 (6.8)	16 (7.2)	13 x 6 x 44 (33 x 15 x 112)	1.9 (.053)

FP SERIES, FLAT PANEL ANTENNAS

FP-5-5-18	0.5 (0.15)	Cardboard	3 (1.4)	4 (1.8)	11 x 11 x 7 (27 x 27 x 17)	0.23 (.006)
FP1-5-24	1 (0.3)	Cardboard	5 (2.3)	8 (3.6)	16 x 16 x 5 (40 x 40 x 12)	0.57 (.016)
FP2-5-28	2 (0.6)	Cardboard	10 (4.5)	18 (8.2)	27 x 25 x 6 (68 x 63 x 15)	2.27 (.06)

TERMS AND CONDITIONS

Acceptance: Acceptance of, or order resulting from proposals or quotations, shall not be binding upon Radio Waves until accepted in writing at Radio Waves Billerica, MA. The term "acceptance" as used shall include an acceptance letter or Radio Waves standard acceptance form. All orders are subject to Radio Waves standard terms and conditions of sale. Clerical errors are subject to correction. In the event of conflict between unit price and extended quantity price, unit prices shall govern. The laws of the Commonwealth of Massachusetts shall govern any disputes or sale.

Terms of Payment: All invoices are payable within thirty days after shipping date or date of services rendered, unless other terms are specified by Radio Waves. In all cases, if shipment delay is requested by the Purchaser, payment shall become due at Radio Waves' option, from the date on which Radio Waves is prepared to make shipment. If, in Radio Waves' judgement, the financial condition of Purchaser does not justify continuation of production or shipment on the terms of payment specified, Radio Waves shall cancel any unfilled order or part hereof unless Purchaser shall, upon notice, pay for all merchandise delivered.

Change Order or Cancellation: Any order or contract may be changed or canceled by the purchaser but only upon prior agreement with Radio Waves as to the amount of the change order or cancellation charges. Upon request Radio Waves will inform Purchaser as the amount of such charge.

Shipment: Unless otherwise specified, shipment shall be made F.O.B. shipping point either freight collect or prepaid. In the event of prepayment, Radio Waves will invoice the freight charges separately. In the absence of specified shipping instructions, method of shipment will be determined by Radio Waves. Unless directed by the Purchaser, full invoice value will be declared for deliveries by air freight, rail-way express, air express or motor freight.

Warranties: Radio Waves warrants that all equipment of its manufacture to be free from defects caused by faulty material or poor workmanship, but its liability under said warranty is limited to the obligation to repair or at Radio Waves option, to replace without charge, F.O.B. shipping point, any part found defective under normal use and service within five years of shipment provided:

- a) Radio Waves is promptly notified in writing upon discovery of such defects.
- b) The original parts are returned to Radio Waves, transportation charges prepaid, and
- c) Radio Waves analysis shall disclose to its satisfaction that such defects have not been caused by abuse after delivery to the original freight carrier.
- d) All specifications are subject to change without notice. Equipment not manufactured by Radio Waves is subject to the manufacturer warranty.

Delays: Radio Waves shall in no case incur any liability, consequential or otherwise, for delays or failure to deliver for any cause beyond its reasonable control, including the generality of the foregoing, acts of God, or the public enemy; acts of the United States, any state or territory.

Taxes: The prices given do not include Federal Exise Tax unless specifically noted, and do not include Federal, State or Local taxes upon or measured by sales or use. Any such taxes in effect at the time of shipment will be billed separately and will be due and payable in 30 days of shipment, unless properly executed Tax Exemption Certificates are furnished to Radio Waves.

Consequential Damages: Radio Waves shall not be liable for consequential damages of any nature with respect to any merchandise or service sold, delivered or rendered.

Return of Material Authorization: (RMA's) Adherence to Radio Waves terms and conditions is mandatory in order to obtain proper replacement of warranty material, repairs or credit. Radio Waves assumes no responsibility nor any liability for material returned without prior authorization. RMA requests should be made to: **Radio Waves, Inc., Customer Service Department, 495R Billerica Ave., N. Billerica, MA 01862, USA.** This request should be made prior to the shipment of any item. This request should also contain the name, address and telephone number of the returning party so that information may be submitted as required. If an approval for return is approved, an RMA form and number with shipping instructions will be forwarded. The RMA number shall be written on the outside of the packaging. The material should be properly packaged and returned to Radio Waves, transportation prepaid. Radio Waves assumes no responsibility, no liability for any items returned not complying with this procedure.

Minimum Charges: Minimum charge on each order will be \$150.00 and all orders where the quantity ordered has a total price of \$150.00 or less will be billed \$150.00.

Interest Charge on Late Payment: Interest shall be due and charged on all invoices remaining overdue for 10 days or more. Interest shall be computed at the rate of 1.5% per month (18% annum) and shall be applied to each overdue month or fraction thereof.

Collections and Assignments: Radio Waves shall have the right to assign to financial institution monies that are 90 days overdue and are deemed non-collectable. All fees incurred by Radio Waves are subject to collection and added to the original invoice.

WARRANTY INFORMATION

Radio Waves Incorporated

Five Year Warranty for Microwave Antennas

Notwithstanding different warranty provisions stated in Radio Waves Incorporated Standard Terms and Conditions, the warranty applicable to Radio Waves-manufactured microwave antennas shall be as follows:

Seller warrants that any Radio Waves microwave antenna is transferred rightfully and with good title; that it is free from any lawful security interest or other lien or encumbrance unknown to Customer; and that for a period of sixty (60) months from the date of shipment from Radio Waves factory, such equipment will be free from defects in material and workmanship which arise under proper and normal use and service. Customer's exclusive remedy hereunder is limited to Seller's correction (either at its plant or at such other places as may be agreed upon between Seller and Customer) of any such defects by repair or replacement at no cost to the Customer provided that the cost of any transportation in connection with the return of the equipment for the purpose of repair or replacement shall be borne by Customer. The provisions of this warranty shall be applicable with respect to any equipment, which Seller repairs or replaces pursuant to it. SELLER MAKES NO WARRANTY, EXPRESS OR IMPLIED, OTHER THAN AS IS SPECIFICALLY STATED ABOVE. EXPRESSLY EXCLUDED ARE ANY IMPLIED WARRANTIES OF MERCHANTABILITY OR FITNESS FOR PURPOSE. THE FOREGOING SHALL CONSTITUTE ALL OF SELLERS LIABILITY (EXCEPT AS TO PATENT INFRINGEMENT) WITH RESPECT TO THE EQUIPMENT. IN NO EVENT SHALL SELLER BE LIABLE FOR SPECIAL, CONSEQUENTIAL OR INCIDENTAL DAMAGES, INSTALLATION COSTS, LOST REVENUE OR PROFITS, OR ANY OTHER COSTS OF ANY NATURE AS A RESULT OF THE USE OF EQUIPMENT MANUFACTURED BY THE SELLER, WHETHER USED IN ACCORDANCE WITH INSTRUCTIONS OR NOT. UNDER NO CIRCUMSTANCES SHALL SELLER'S LIABILITY TO CUSTOMER EXCEED THE ACTUAL SALES PRICE OF THE EQUIPMENT PROVIDED HEREUNDER. No representative is authorized to assume for Seller any other liability in connection with the equipment.



The Best Warranty in the Industry!

NOTES

NOTES

NOTES

NOTES

NOTES

NOTES

NOTES

NOTES

NOTES